

apricot

Information contained in this document is subject to change without notice and does not represent a commitment on the part of Apricot Computers Limited. The software described in this manual is furnished under a license agreement. The software may be used or copied only in accordance with the terms of this agreement.

It is against the law to copy any disk supplied for any purpose other than the purchaser's personal use.

All rights reserved; no use or disclosure without written consent.

Copyright © Apricot Computers Limited 1993

Published by
Apricot Computers Limited
3500 Parkside
Birmingham Business Park
B37 7YS

 MITSUBISHI ELECTRIC

Printed in the United Kingdom

Part no. 15177031

Revision 01

Contents

SETUP

- Introduction 3
- Invoking SETUP 3
- The SETUP screen 4
- Controlling SETUP using the keyboard 6
- System Autoconfiguration 6
- Opening screen 7
- Change disk types 12
- Advanced options 13
- Exiting SETUP 19

Installing add-ons

- Introduction 21
- Expansion cards 23
- Memory 26
- Processor upgrades 32
- 5.25" drives 40
- 3.5" hard disk drive 47

Appendix A: Configuring expansion cards 53

Appendix B: Motherboard video adapter 65

- Video disable jumper 65
- Video feature connector 67

Appendix C: Approved SIMMs 69

SETUP

Introduction

The Apricot XEN motherboard is fitted with a small area of memory which is used to store information about the configuration of the computer. The computer's configuration is modified using a SETUP utility provided in Read Only Memory (ROM) on the motherboard.

A rechargeable battery on the XEN motherboard maintains the configuration memory when the computer is switched off.

Invoking SETUP

Each time the XEN is switched on, or rebooted, it runs through a self test procedure. During this period the SETUP utility can be invoked by pressing the ALT+S key combination.

The XEN can boot in two ways, it can use a graphical boot screen, or a conventional text based boot screen. During graphical boot a Setup button is displayed, SETUP can only be invoked while the button is not greyed out. During text boot a prompt appears on the screen, while the prompt is visible SETUP can be invoked.

There may be a delay of a few seconds, while the self test procedure is completed, before the SETUP screen appears.

The SETUP screen

The simplest way to use SETUP is with a mouse, just move the cursor to the option you want to select and click with the left mouse button. The illustration below identifies the elements that make up the SETUP screen.

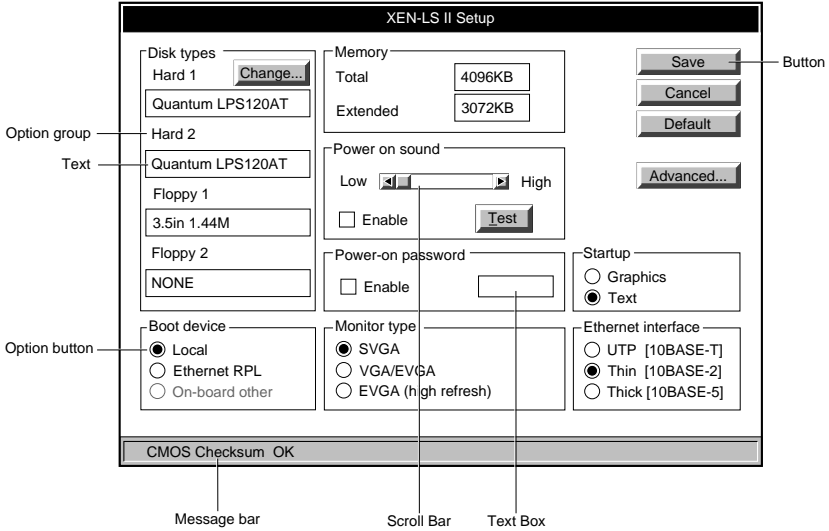

Option group

These are used to collect a number of related, or exclusive, options under a common heading.

Check box

Check boxes are used where any number of the options in the group may be selected. Select or de-select a check box by pointing and clicking in the box with the mouse.

Option button

These are used for exclusive options. Beside each option is a circle, only one circle is highlighted at any given time. If you point and click on an option the highlight will transfer to it.

Scroll bar

Scroll bars behave like slide controls. They are adjusted by pointing and clicking on the arrows at each end of the bar.

Text box

These are provided when the user has to enter text. Point and click in the text box, then enter the text required and press ENTER.

Text

The SETUP utility displays some information about your system that is detected automatically and cannot be altered. For example, the amount of memory installed in the system is detected and displayed, for information only.

Buttons

Buttons carry out the action indicated by the text on the button.

Message line

A message line at the bottom of the screen contains information about SETUP.

Greyed out options

Where an option is greyed out it indicates that it cannot currently be selected, or used. There could be a variety of reasons for this, for example: the computer may not support the option, or an associated option may have to be enabled in order for the greyed out option to be valid.

Controlling SETUP using the keyboard

If you are unable to use a mouse, you can use the keyboard to move around and select the SETUP options.

- | | |
|------------|---|
| TAB | Moves you round the option groups, and buttons. An alternative method is to hold down the ALT key and press the letter which corresponds to the one underlined in the title of the group. |
| ARROW KEYS | Once you are in an option group, use the arrow keys to move through the options. The system will highlight an entry to show which option is currently selected. |
| SPACE BAR | Press the space bar to set the highlighted option. |
| ENTER | Confirms buttons. |

When the changes in a screen are complete are complete, select the **SAVE** button and press **ENTER**. To abandon your changes, select the **CANCEL** button and press **ENTER**.

System Autoconfiguration

If the system configuration has changed since the last time the computer was booted, SETUP will be invoked automatically.

Opening screen

Disk Types

Hard disk

The XEN supports a maximum of two IDE hard disk drive(s). The type of drive fitted is displayed in these two text boxes.

Floppy disk

The XEN can be fitted with one or two floppy drives. These text boxes are used to display the type of drive fitted.

There is no need to change the floppy drive type unless you are adding a drive.

Change

The **Change** button accesses a screen which allows you to select the type of each floppy drive, and provides for the possible inclusion of user-defined hard disk drives.

The *Change disk type* screen is described in more detail later in this section.

Boot device

The boot device option group allows you to select where you want the XEN to look for an operating system when it is switched on or rebooted. The group contains three option buttons, these choose between booting from a hard or floppy disk in the computer, and remotely across the on-board Ethernet interface using different types of remote boot.

If you make an inappropriate selection it may result in the computer failing to find an operating system and being unable to boot.

Before selecting a remote boot option check with your network administrator.

Local

This should be selected if the computer is to boot from an internal hard disk or floppy drive.

It should be noted that when one of the remote boot schemes described below is enabled it is not possible to boot the computer from a local device. If you wish a XEN, that normally boots remotely using the on-board Ethernet interface, to boot from a local device, you must first use SETUP to select Local in the boot device option group.

Note

This option should be selected if you want the computer to boot remotely from a server using a network interface on an expansion card.

Ethernet

If the computer is connected to an Ethernet network using the on-board Ethernet interface, and it is to boot remotely from a server using the RPL (Remote Program Load) scheme, enable this option.

Other

This option is provided for possible future implementation of other remote boot methods for the on-board Ethernet interface. It is currently greyed out.

Memory

The memory text box displays a count of the amount of memory installed in the system. The contents of the text box cannot be edited and is displayed for information only.

Separate counts of total and extended memory are displayed.

Power-on sound

When this option is enabled the XEN audio subsystem provides an audible indication that the system has been switched on.

Volume

The volume control adjusts the output level of the Power-On Sound. Use it to adjust the volume to suit the computer's location.

Test

Use the Test button to preview the Power-On Sound to ensure that you have set it to a suitable level.

Set Power-on Password

The XEN supports a power-on password. If enabled this password must be entered every time the system is powered up or rebooted. If you have Apricot LOC Technology enabled the power on password cannot be used.

When the power-on password is enabled the text box can be selected and a password entered. The password has a minimum length of 1 character and a maximum length of 7 characters.

Monitor type

There are three option buttons in this group: SVGA, VGA/EVGA and EVGA (high refresh). The three options alter the timings of video signals provided by the XEN video connector to suit a variety of different types of monitor.

It is important to ensure that you have made the correct selection.

SVGA

This option should be chosen for SVGA monitors. These are monitors that support 800x600 non-interlaced and 1024x768 interlaced video modes in addition to standard VGA modes.

VGA/EVGA

This option should be chosen for VGA monitors, and for EVGA monitors to run at normal refresh rates, typically 60Hz. EVGA monitors support 800x600 and 1024x768 non-interlaced video modes in addition to standard VGA modes.

VGA monitors will not display resolutions greater than 640x480 correctly.

EVGA (high refresh)

This option can be used if your EVGA monitor supports high refresh rates. If this option is chosen: 640x480, 800x600 and 1024x768 display modes use high refresh rates, typically 72Hz.

The video timings in these high refresh rate modes are VESA compatible. Some monitors which are capable of displaying these modes may need the CVSHELL utility supplied on the Apricot Drivers disks to adjust the position of the display on the screen.

VGA and SVGA monitors will not work if this option is selected.

Video modes

The XEN motherboard video adapter can generate a wide variety of video outputs. In addition to standard VGA modes it supports a number of enhanced modes.

In order to display these enhanced modes correctly you must ensure that the correct monitor type is selected. Selecting the wrong monitor type could result in nothing being displayed.

To take advantage of these modes suitable display drivers must be used. A set of drivers for popular applications is supplied with your computer. Installation instructions are provided in help files supplied with the drivers.

Startup

Graphics

When graphics is selected the initial boot screen is displayed in graphical format.

Text

When text is selected a text based boot screen is used.

Ethernet interface

These three option buttons are used to select the type of Ethernet the XEN is connected to.

Warning

You must select the correct interface. If you choose the wrong one you will not be able to use the network connection.

Advanced

This button activates a screen of advanced options. Many of the options affect the operation of the motherboard, and should only be changed by the technically competent user.

The operation of the *Advanced* screen is described in detail later in this section.

Change disk types

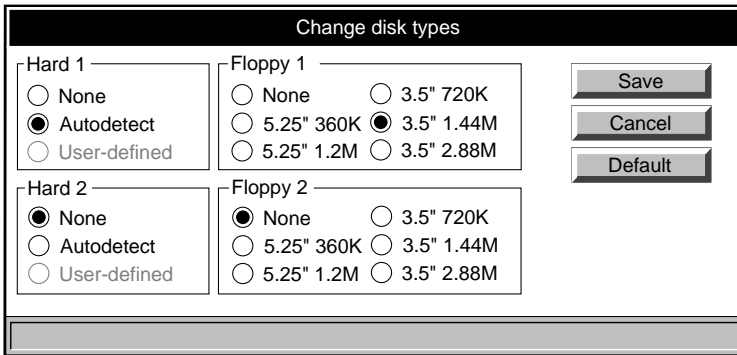

Change disk types		
Hard 1 <input type="radio"/> None <input checked="" type="radio"/> Autodetect <input type="radio"/> User-defined	Floppy 1 <input type="radio"/> None <input type="radio"/> 3.5" 720K <input type="radio"/> 5.25" 360K <input checked="" type="radio"/> 3.5" 1.44M <input type="radio"/> 5.25" 1.2M <input type="radio"/> 3.5" 2.88M	<input type="button" value="Save"/> <input type="button" value="Cancel"/> <input type="button" value="Default"/>
Hard 2 <input checked="" type="radio"/> None <input type="radio"/> Autodetect <input type="radio"/> User-defined	Floppy 2 <input checked="" type="radio"/> None <input type="radio"/> 3.5" 720K <input type="radio"/> 5.25" 360K <input type="radio"/> 3.5" 1.44M <input type="radio"/> 5.25" 1.2M <input type="radio"/> 3.5" 2.88M	

Hard 1 and 2

For Apricot supplied drives always use Autodetect. This will ensure that the system uses the correct parameters for the drive.

The user-defined entry is for possible future enhancement to allow non-standard drives to be used.

Floppy 1 and 2

These two option groups allow to select which type of floppy drive is installed.

Floppy 1 will always be a 3.5" device, 1.44M being the standard fitment.

Floppy 2, if fitted, will usually be a 5.25" 1.2M device.

The other options are included for compatibility reasons, and for possible future enhancement.

Advanced options

Disable motherboard	
<input type="checkbox"/>	Serial port 1
<input type="checkbox"/>	Serial port 2
<input type="checkbox"/>	Parallel port
<input type="checkbox"/>	Digital audio system
<input type="checkbox"/>	Hard disk controller
<input type="checkbox"/>	Floppy disk controller
<input type="checkbox"/>	CD-ROM interface
<input type="checkbox"/>	Ethernet coprocessor
<input type="checkbox"/>	BIOS copy at 16MB
<input checked="" type="checkbox"/>	Memory hole at 16MB
<input type="checkbox"/>	i486 cache
<input type="checkbox"/>	External cache
<input type="checkbox"/>	Expansion slots

Adapter Memory		Shadow Wrt.Protect	
DC000-DFFFF	<input type="checkbox"/>	<input type="checkbox"/>	
D8000-DBFFF	<input type="checkbox"/>	<input type="checkbox"/>	
D4000-D7FFF	<input type="checkbox"/>	<input type="checkbox"/>	
D0000-D3FFF	<input type="checkbox"/>	<input type="checkbox"/>	
CC000-CFFFF	<input type="checkbox"/>	<input type="checkbox"/>	
C8000-CBFFF	<input type="checkbox"/>	<input type="checkbox"/>	
C4000-C7FFF	<input type="checkbox"/>	<input type="checkbox"/>	
C0000-C3FFF	<input type="checkbox"/>	<input type="checkbox"/>	

Motherboard BIOS		Shadow Wrt.Protect	
System [E0000-FFFFF]	<input checked="" type="checkbox"/>	<input type="checkbox"/>	
Video [C0000-C7FFF]	<input checked="" type="checkbox"/>	<input type="checkbox"/>	

ISA bus	
Bus speed	I/O decoding
<input type="radio"/> Slow	<input checked="" type="radio"/> 10 bit
<input checked="" type="radio"/> Fast	<input type="radio"/> 16 bit

Disable motherboard

These check boxes allow you to selectively disable motherboard features. You should only disable any of these functions if you are sure it is appropriate.

Serial port 1, 2, Parallel port

Checking a box disables the port associated with that box. You should only disable a port if you are sure that you do not want to use it.

Disabling a port in SETUP disables the relevant motherboard hardware and frees the interrupt associated with the port. Information on interrupts and their usage is given in Appendix A at the rear of this guide.

Digital audio system

Checking this box disables the Apricot audio feature. You should only disable the audio system if you are not using it.

Note

This check box disables the Apricot audio hardware, it has no affect on the standard ISA sound capabilities.

Disabling the Apricot audio system frees the interrupt, and the DMA channels associated with the audio system. Information on interrupts, DMA channels, and their usage is given in Appendix A at the rear of this guide.

Hard disk controller

Checking this box disables the motherboard hard disk drive interface. You should only disable the interface in a system without a hard disk drive.

Disabling the interface in SETUP disables the relevant motherboard hardware and frees the interrupt associated with the it. Information on interrupts and their usage is given in Appendix A at the rear of this guide.

Floppy disk controller

Checking this box disables the motherboard floppy drive interface. Since all XEN systems are supplied fitted with at least one diskette drive you should not normally disable the interface.

Disabling the floppy drive interface in SETUP disables the relevant motherboard hardware and frees the interrupt and the DMA channel associated with it. Information on interrupts, DMA channels, and their usage is given in Appendix A at the rear of this guide.

CD-ROM interface

Checking this box disables the motherboard CD-ROM interface. You should only disable the interface in a system without a CD-ROM drive.

Disabling the CD-ROM interface in SETUP disables the relevant motherboard hardware and frees the interrupt and the DMA channel associated with it. Information on interrupts, DMA channels, and their usage is given in Appendix A at the rear of this guide.

Ethernet coprocessor

Checking this box disables the Ethernet coprocessor. You should only disable the Ethernet coprocessor if you are not using it.

Disabling the Ethernet coprocessor in SETUP disables the motherboard hardware and frees the interrupt associated with the coprocessor. Information on interrupts and their usage is given in Appendix A at the rear of this guide.

BIOS copy at 16MB

In an ISA compatible system a copy of the system BIOS appears at 16 Mbytes. Checking this box removes that copy of the system BIOS from the memory map.

In systems fitted with up to 16 Mbytes of RAM the box can be either checked, or unchecked, it is unlikely to have a significant effect.

In systems fitted with more than 16 Mbytes of RAM the box must be checked.

Memory hole at 16MB

This option is used to enable or disable a hole in motherboard memory. The hole, when enabled, appears from 16M-128k to 16M.

This option should normally be disabled, and there is no hole in the memory map. The hole should only be enabled when the system RAM capacity is 16Mbytes or greater, and you have an expansion card which uses memory mapped I/O.

i486 cache

Checking this box disables the cache memory inside the i486 processor. There should normally be no reason to disable the processor cache, it will result in a performance decrease.

Some old software which is speed sensitive may not work properly with the cache enabled. This problem is uncommon, and this option is provided as a safety net.

External cache

Checking this box disables the external cache, the cache outside the i486. There should normally be no reason to disable this cache, it will result in a performance decrease.

Some old software which is speed sensitive may not work properly with the cache enabled. This problem is uncommon, and this option is provided as a safety net.

If your XEN is not equipped with the external cache this option will be greyed out.

Expansion slots

Checking this box disables all three expansion slots.

This option would not normally be used, however under certain circumstances it may be useful. For example, if you install an expansion card and the computer fails to boot when you power it up. You may be able to use this SETUP option to disable the expansion slots, and get the computer to boot.

Motherboard BIOS

The system and VGA BIOS on the motherboard is stored in ROM which has long access times. Enabling BIOS shadowing enhances the performance of the system by copying the contents of the BIOS ROM into RAM.

By copying the BIOS into RAM the system takes advantage of the shorter access times of RAM. An additional benefit is that shadowed ROM spaces are cached gaining a further performance advantage.

Shadow

Checking this box enables BIOS shadowing for the associated address range.

Write protect

Checking this box enables write protection for the associated shadowed address range.

The normal state for this option will be disabled, the box not checked. It is extremely rare for software to attempt to write to ROM address ranges, and leaving write protection disabled results in a performance advantage.

If you enable write protection then shadowed ROM spaces can never be overwritten, this is safer, but results in lower performance.

Adapter BIOS

BIOS on the expansion cards is stored in ROM which has long access times. Enabling BIOS shadowing enhances performance by copying the contents of the ROM into RAM.

By copying the BIOS into RAM the system takes advantage of the shorter access times of RAM. An additional benefit is that shadowed ROM spaces are cached gaining a further performance advantage.

Shadow

Checking this box enables BIOS shadowing for the associated address range.

Warning

Shadowing is only appropriate for adapter ROM. It must never be enabled for adapter card RAM in these regions.

Write protect

Checking this box enables write protection for the associated shadowed address range.

The normal state for this option will be disabled, the box not checked. It is extremely rare for software to attempt to write to ROM address ranges, and leaving write protection disabled results in a performance advantage.

If you enable write protection then shadowed ROM spaces can never be overwritten, this is safer, but results in lower performance.

ISA bus

Bus speed

These two options, in conjunction with a switch on the motherboard, allow the speed of the ISA bus to be varied.

When this option is set to Fast, and the switch on the motherboard is set to 8MHz the bus is fully compatible with the ISA specification.

If this option is set to Slow and the switch on the motherboard is set to 8MHz the bus is slightly slower than the ISA specification.

If this option is set to Slow and the switch on the motherboard is set to 10MHz the bus is slightly faster than the ISA specification.

If this option is set to Fast and the switch on the motherboard is set to 10MHz the bus is significantly faster than the ISA specification.

I/O decoding

These two option buttons allow you to choose whether 16 or 10 address bits are decoded for I/O cycles to the ISA bus.

16 bit decoding allows access to the full 64K I/O space on the ISA bus.

10 bit decoding is slightly quicker, but restricts I/O accesses on the ISA bus to the bottom 1K, from 0h to 399h.

Exiting SETUP

Use either the **SAVE** or **CANCEL** button to close the *Change disk type* or *Advanced* windows.

The **SAVE** button will implement any changes that you have made in a screen. The **CANCEL** button exits that screen without implementing any changes.

Selecting **Save** or **Cancel** from the opening screen will exit SETUP. If any changes have been made the computer will reboot when you exit SETUP.

Installing add-ons

Introduction

This section contains instructions on installing add-ons and upgrades in the XEN. The areas covered include:

- * expansion cards
- * additional memory
- * processor upgrades
- * additional drives

This document should be your only source of information when installing any of these.

Read this document before purchasing an add-on or upgrade. If, having read the relevant instructions, you are not confident about installing the upgrade, you may wish to have your supplier or service organisation install it for you.

Before you start installing the upgrade you should be thoroughly familiar with all the relevant instructions in this guide and any appropriate sections of your *Owner's Handbook*.

Warning

Never carry out any work on the equipment with power applied. Always switch off at the mains and remove the power lead from the equipment before starting work.

Appendices at the rear of this section provide information on expansion card configuration, information about the motherboard video disable jumper, a pinout of the motherboard video feature connector and a list of approved SIMMs.

The only tool required to complete the installation of any of the upgrades is a small cross-head screwdriver.

Inside the system unit

The illustration below identifies the major components inside the XEN system unit that are affected by the installation instructions later in this section.

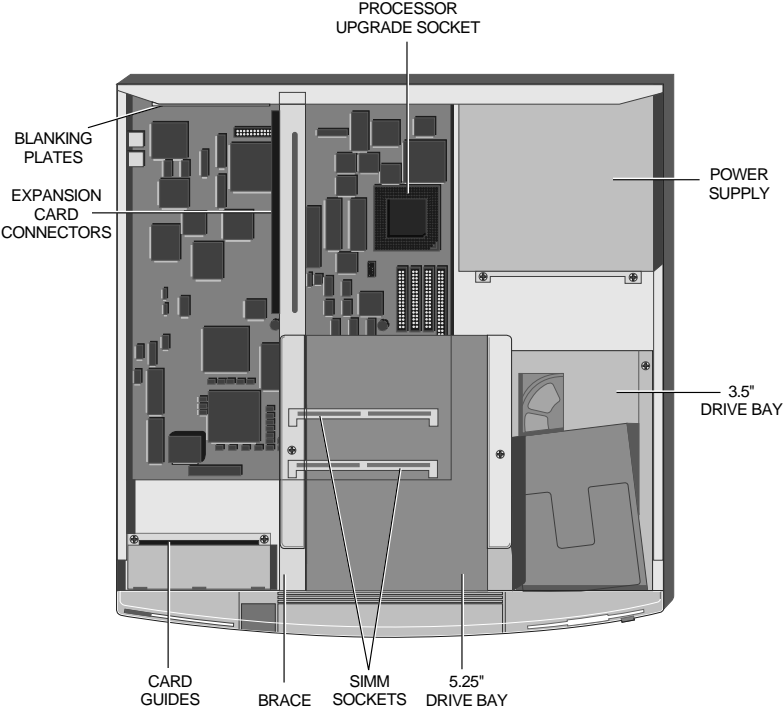

Expansion cards

Installation

The XEN provides three slots for the installation of expansion cards. These slots are ISA (also known as AT) compatible and can supply three expansion cards with a total power consumption of 45W.

Installation of an expansion card in the XEN is a simple process requiring the removal of only the system unit cover and a blanking plate. The following instructions and illustrations describe how to install a card in a simple step-by-step sequence.

1. Power the system down.
2. Take suitable anti-static precautions and remove the system unit cover.

If you are unfamiliar with Apricot's recommended anti-static precautions and/or the process of removing the system unit cover refer to your *Owner's Handbook*.

3. With the system unit cover removed, the space for expansion cards will be visible. It is on the left side of the system unit behind the activity indicators and the volume control. Use the illustration below to help you identify this area.

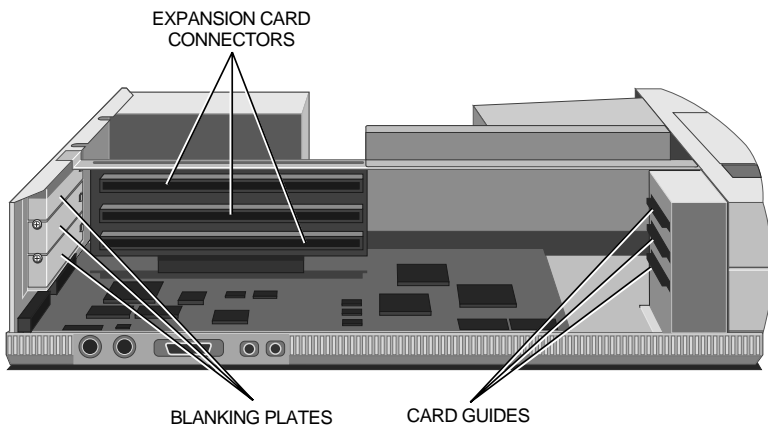

At the rear of the area are three metal blanking plates, one for each expansion card slot. These plates cover slots in the rear of the system unit which will be used by expansion cards.

At the front of the area are three guides. These ensure that the front edge of any full length card is secured.

4. The blanking plates described above are each secured by a screw. Using the following guidelines decide which of the available slots you wish to install the card in, then remove the appropriate blanking plate.

In general it is easiest to start with the lowest slot and work towards the top, but there are a couple of exceptions. If you are installing a card which uses the video feature connector on the motherboard then it is best to install the card in the lowest slot. If you are installing a drive controller card that you want to connect to a drive in the 5.25" drive bay, then it is easiest to install it in the top slot.

To remove the blanking plate, first unscrew the securing screw, then slide the plate out of its slot. Keep the screw, you will use it later to secure the card.

5. You are now ready to install the card. However, before you do so you must first ensure that the card is correctly configured for your system.

Information on configuring cards for use in the XEN is given in the *Configuring expansion cards* appendix at the rear of this guide. Use this information in conjunction with the documentation supplied with your card to configure the card so that it will not clash with any of the features on the XEN motherboard, or any other expansion cards already installed.

A table for noting the configuration of cards is included in Appendix A.

6. Position the expansion card alongside the slot in which you wish to install it. Align the rear of the card with the slot in the rear of the system unit, and, if the card is full length, the front of the card with the card guide.

Note

If the card uses the video feature connector on the motherboard, you must plug the video feature cable into the motherboard socket before you install the card.

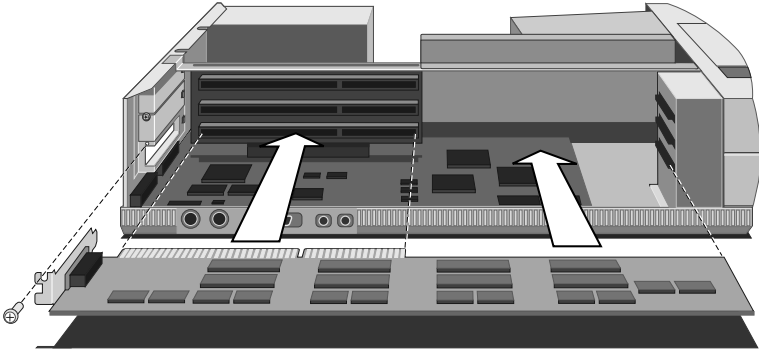

7. Slide the card into the slot ensuring that the card edge connector engages correctly with the expansion card connector.
8. Carefully push the card fully home. Do not apply excessive pressure.
9. Secure the card by replacing the screw that you removed in step 4.
10. Connect any signal cables to the card.

Note

If you have installed a video display adapter that is CGA, EGA or VGA compatible you must disable the motherboard video adapter by removing a jumper. If you do not remove this jumper, it is unlikely that either the video card or motherboard video adapter will operate correctly. The jumper is identified in Appendix B.

11. Replace the system unit cover.

Memory

Configurations

The XEN motherboard is fitted with 4 Mbytes of on-board memory, and sockets for two SIMMs (Single In-line Memory Modules). Each socket can be empty, or fitted with a SIMM of 4, 8, 16 or 32Mbytes capacity.

The sockets support standard 70nS, 4 Mbyte (1MX36), 8 Mbyte (2MX36) and 16 Mbyte (4MX36) SIMMs. The 32 Mbyte SIMM must be obtained from Apricot, standard 32 Mbyte SIMMs will not work in the XEN. The table below identifies the possible memory capacities using the various SIMM combinations.

MM1 capacity	MM2 capacity	Upgrade capacity	Motherboard memory	Available memory
-	-	-	4	4
4	-	4	4	8
8	-	8	4	12
16	-	16	4	20
32	-	32	4	36
4	4	8	4	12
4	8	12	4	16
4	16	20	4	24
8	8	16	4	20
8	16	24	4	28
16	16	32	4	36
32	4	36	4	40
32	8	40	4	44
32	16	48	4	52
32	32	64	4	64

Notes

1. *When a 32Mbyte SIMM is installed in MM2 the motherboard memory is disabled.*
2. *Only gold plated SIMMs may be used in the XEN SIMM sockets.*
3. *A list of approved SIMMs is given in Appendix C.*

It should be noted that, for all combinations the SIMM in MM1 can be swapped with that in MM2. In every case the computer will operate correctly when it is powered up, and in most cases there will be no difference in the operation of the computer.

There are only two exceptions to this. In the situations given below, although the computer will operate if the SIMMs are swapped it is preferable if the SIMMS are installed as described.

- * If you are upgrading to 24Mbytes of system memory, i.e. you have one 4 and one 16Mbyte SIMM, the 4Mbyte SIMM should always be installed in MM1.
- * If you are installing a 32Mbyte SIMM it should always go in MM1 unless there is a 32Mbyte SIMM in the socket already.

If in either of the cases above you install a 4 or 32 Mbyte in MM2 when you power the system up you will be prompted to swap the SIMMs.

Installation

In order to install a memory upgrade you must:

1. Power the system down.
2. Take suitable anti-static precautions and remove the system unit cover.

If you are unfamiliar with Apricot's recommended anti-static precautions and/or the process of removing the system unit cover refer to your *Owner's Handbook*.

The SIMM connectors are located beneath the 5.25" drive bay. In order to install a memory upgrade you must remove the 5.25" drive bay.

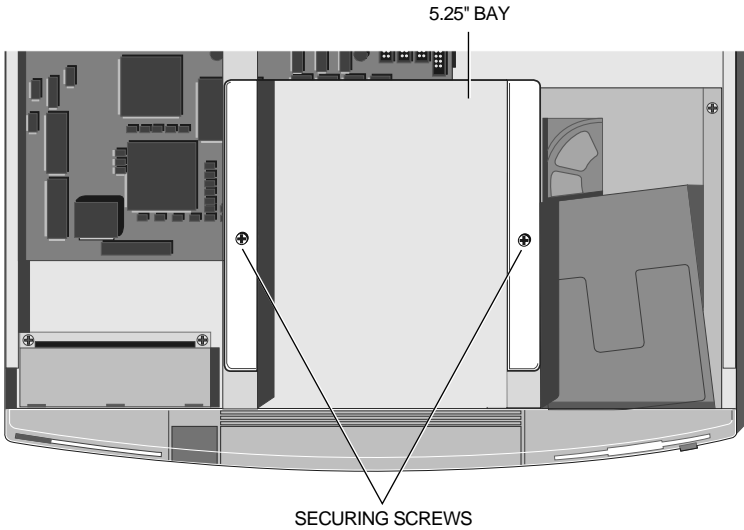

3. If there is a drive fitted disconnect the power and signal cables from the rear of the drive.
4. Remove the two screws that secure the drive bay and slide the bay backwards.
5. Lift the bay out of the system unit and put it down on a safe flat surface.

Removing a SIMM

If you wish to install an upgrade in a SIMM socket which is already occupied you must first remove the existing SIMM.

1. Lever the metal clips on each side of the socket gently away from the SIMM using your forefingers.
2. Place your thumbs on the top edge of the SIMM and move it gently towards the vertical.

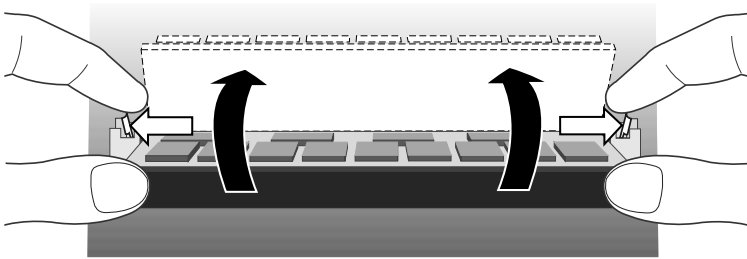

3. When the SIMM has rotated through 20°, taking care to avoid touching any of the components on the SIMM, grip the top corners of the SIMM between thumb and first finger and carefully pull the SIMM out of the socket.

Inserting a SIMM

From the table of possible SIMM combinations decide which SIMM capacity will be installed in the socket. Then install the SIMM.

To fit a SIMM:

1. The SIMM will only install in one orientation. There is a cutout at one end of the SIMM next to the connector strip.

Hold the SIMM with the cutout on the right and metal connector strip nearest the motherboard.

2. Position the SIMM above the socket with the SIMM tilted slightly towards the front of the system unit.

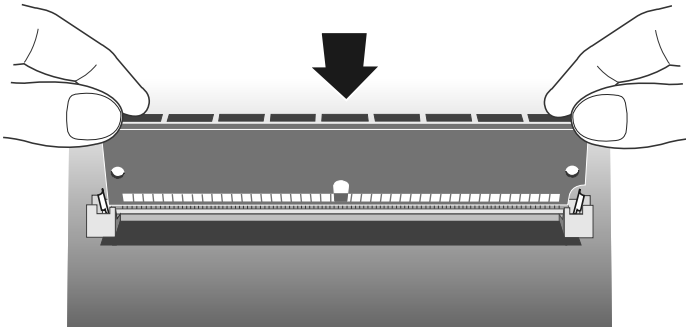

3. Lower the SIMM into the socket, and ensure that the SIMM is properly located in the connector.

4. Pushing gently on the top corners rotate the SIMM towards the horizontal until it clips into place. Do not use excessive force.

If the SIMM will not rotate easily remove it and start again.

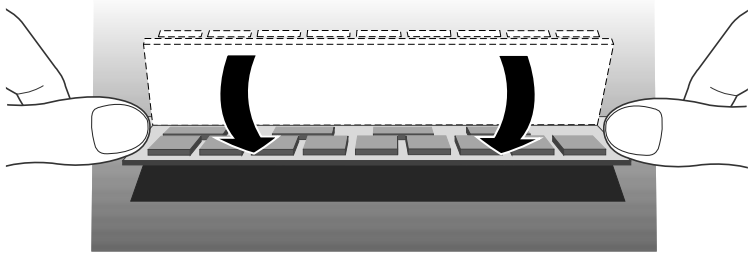

5. If the SIMM is properly located the SIMM should remain in position held by the securing clips, and with a small plastic lug through the holes on either side of the SIMM.

If you want to install a second SIMM repeat the process above. Once you have completed installation you can replace the 5.25" drive bay and reassemble the system.

1. Replace the 5.25" bay in the system unit.
2. Slide the bay forwards until the two holes in the bay line up with those in the hard drive assembly and the system unit brace.
3. Replace the two screws which secure the 5.25" drive bay.
4. If there is a drive in the bay reconnect its power and signal cables.
5. Replace the system unit cover.

The next time you power the system up the SETUP utility will be invoked automatically.

Processor upgrades

The XEN motherboard is fitted with a processor socket that supports any Intel486SX, Intel487SX, Intel486DX, Intel486DX2 or OverDrive processor with a maximum external clock speed of 33MHz.

Any other Intel processor using the same pinout as one of these processors could also be installed, subject to the same 33MHz maximum external clock speed restriction.

The table below lists the possible upgrades for each processor type and speed.

Current Processor	Speed	Upgrade Processor	Speed
Intel486SX	25	Intel487SX	25
		Intel487SX	33
		OverDrive	25
		OverDrive	33
Intel486SX	33	Intel487SX	33
		OverDrive	25
		OverDrive	33
Intel486DX	33	OverDrive	25
		OverDrive	33

Note

This table lists the processors supported by the motherboard. There is no guarantee that any particular upgrade processor will be available at any given time.

Depending on the processor type fitted in your system unit the processor socket may already be occupied. Before installing the upgrade processor you must first check whether the processor socket is occupied, and if it is, remove the existing processor. Instructions on locating the socket and removing a processor are given below.

1. Power the system down.
2. Take suitable anti-static precautions and remove the system unit cover.

If you are unfamiliar with Apricot's recommended anti-static precautions and/or the process of removing the system unit cover refer to your *Owner's Handbook*.

3. Identify the processor upgrade socket.

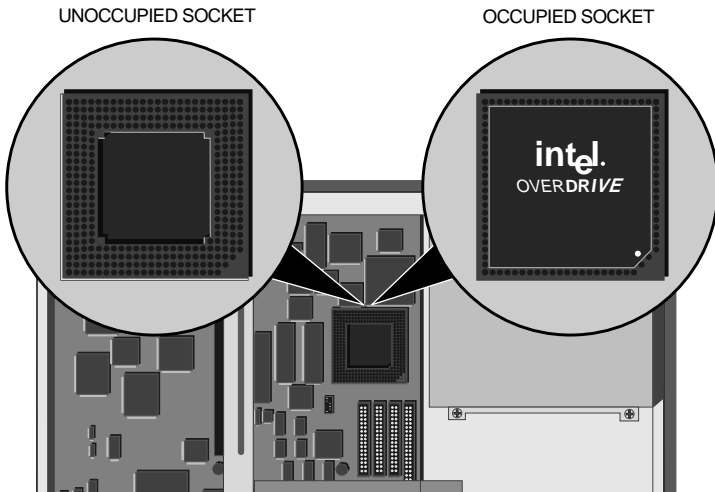

If the socket is not occupied it will look like the close up on the left and you can continue to the installation instructions.

If the socket is occupied it will look like the close up on the right, and you will have to remove it before you can install your upgrade processor.

4. Your upgrade processor is supplied with an extraction tool which resembles a miniature garden rake.

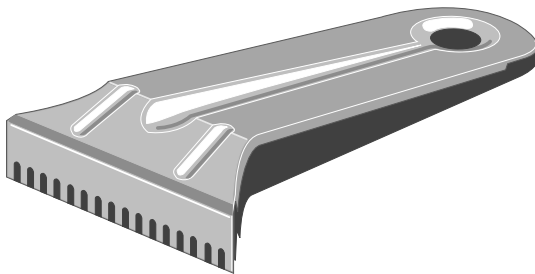

- Carefully insert the prongs of the extractor between the bottom of the processor and its socket. You may need to twist the extractor gently from side to side to work the prongs into place.

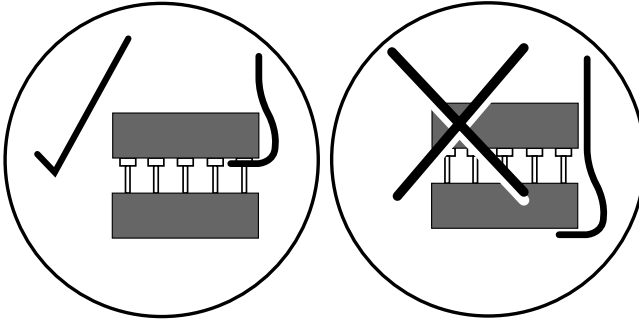

Be careful to ensure that the prongs do not go between the motherboard and the socket.

- Ease the processor up slightly by pushing inwards on the extractor's handle.

Warning

Do not push hard on the handle. The processor must be removed gradually and evenly by working the tool under each edge in turn. Attempting to lift one edge of the processor too far will damage the processor, or the socket, or both.

- Remove the extractor and repeat the process on each edge of the processor, gradually easing the processor out of its socket. If necessary work your way round the processor two or three times.
- Once the processor is free of its socket lift it out of the system unit and place it on the anti-static foam provided with the upgrade processor.

Installation

You should now have identified the upgrade socket, and ensured that it does not have a processor in it. You are ready to install your new upgrade processor.

1. The upgrade processor and socket are keyed to ensure that the processor can only be installed in one orientation.

The inside of one corner of the socket has a key hole, the outside of the same corner is missing three holes. The processor has a positioning guide in the form of a small dot of paint. Use the following illustration to help identify these features.

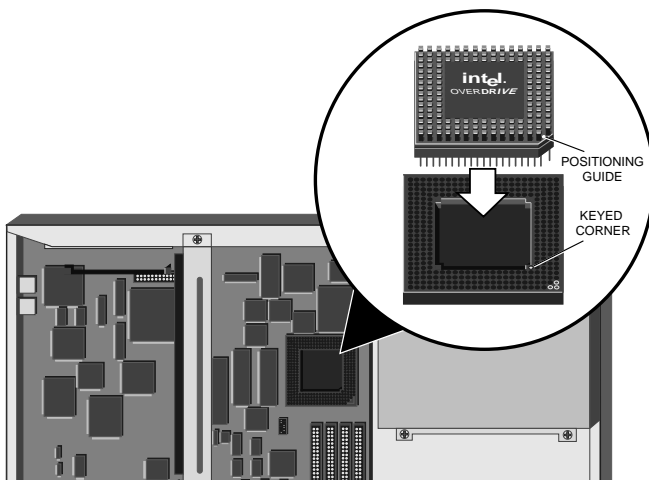

2. Carefully position the upgrade processor above the socket with the positioning guide on the processor over the keyed corner of the socket.

If the upgrade processor does not occupy all four rows of holes it should be positioned centrally as shown below.

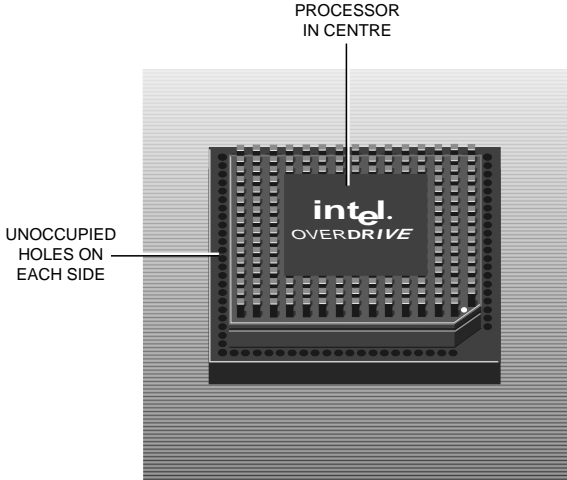

Warning

If the processor is misaligned it will not go into the socket, and any attempt to force it will damage the processor, or the socket, or both.

3. Gently insert the upgrade processor making sure that it is correctly aligned with the socket and that you do not bend or otherwise damage the pins.
4. Once you are certain that all the pins on the processor are in the holes in the socket apply firm even pressure to the top of the processor to seat the pins in the socket.
5. With the upgrade processor installed you must now ensure that the upgrade socket, and motherboard clock speed are correctly configured for your new processor.

Configuring the motherboard overleaf describes how to ensure that when you reassemble your system the new processor will work.

Configuring the motherboard

The XEN motherboard supports a range of processor speeds and the upgrade socket supports a range of processor types. The motherboard clock speed and the upgrade socket are configured using four switches in a set of six by the socket.

It is vital that both the system clock speed, and the upgrade socket configuration are set correctly. Follow the instructions below to check the settings and adjust them as necessary.

1. Use the following illustration to identify the switches.

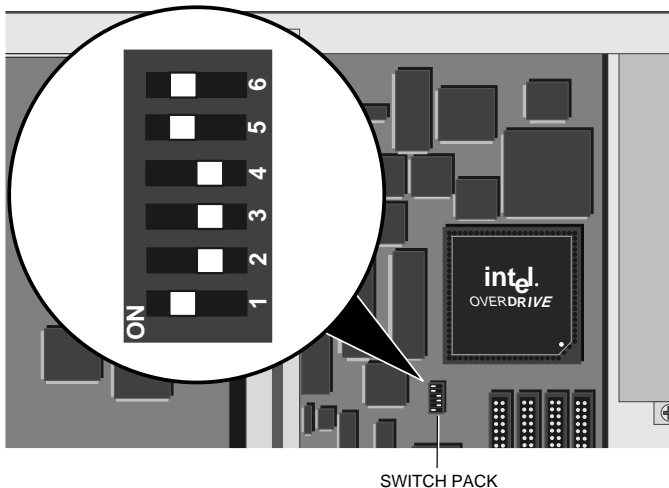

The switches numbered 2 and 3 are used to select the system clock speed. Switches 4 and 5 are used to configure the upgrade socket.

Warning

Under no circumstances should switches 1 and 6 of the switch pack be moved. It is essential that both switch 1 and switch 6 are in the on position.

- From the table below, and the label on your upgrade processor or its packaging, decide which processor type you have installed.

Since the Intel487SX and OverDrive upgrade processors require the same configuration you will normally set switches 4 and 5 to the Off/Off position. The other selections are for processors normally installed during manufacture.

Switch		Processor
4	5	
off	off	Intel487SX/OverDrive Upgrade
off	on	Intel486DX/Intel486DX2/ OverDrive Replacement
on	off	Intel486SX
on	on	not used

- Having decided which selection you require check the positions of switches 4 and 5, and if necessary move them to the appropriate position.

The easiest way to move the switches is with the point of a pencil or small screwdriver.

- From the table below, and the label on your upgrade processor, or its packaging decide which system clock speed you need to select.

Switch		Clock speed (MHz)
2	3	
on	on	16
on	off	20
off	on	25
off	off	33

You will almost certainly want to set the clock speed to either 25 or 33MHz.

If you have installed an Intel487SX you must set the system clock speed to match the speed of the coprocessor.

If you have installed an OverDrive processor you should set the system clock speed to match the external interface speed of the processor. OverDrive processors use Intel's clock doubling technology and the processor runs at twice the speed of its interface to the motherboard.

The labelling on the OverDrive processor or its packaging should make it clear what its external interface speed is.

5. Having decided which selection you require check the positions of switches 2 and 3, and if necessary move them to the appropriate position.

The easiest way to move the switches is with the point of a pencil, or a small screwdriver.

6. You should by now have: identified the upgrade socket, and if necessary removed the processor fitted in it, installed the new processor, configured the upgrade socket, and set the system clock speed. If you are uncertain about having completed any of these steps, go back to the beginning and check the steps you carried out against the installation instructions.
7. Once you are satisfied that you have installed the upgrade and configured the system correctly, reassemble the system.

5.25" drives

The 5.25" drive bay in the XEN system unit can contain any standard size half height 5.25" device. Apricot supplies a range of tape and CD-ROM drives, and a 5.25" floppy drive, for this bay.

The following instructions describe the installation of a drive in the bay. The *Generic* instructions apply to all drives, and describe the physical installation of a drive.

Instructions specific to each drive type are given after the generic instructions.

Generic

1. Power the system down.
2. Take suitable anti-static precautions and remove the system unit cover.

If you are unfamiliar with Apricot's recommended anti-static precautions and/or the process of removing the system unit cover refer to your *Owner's Handbook*.

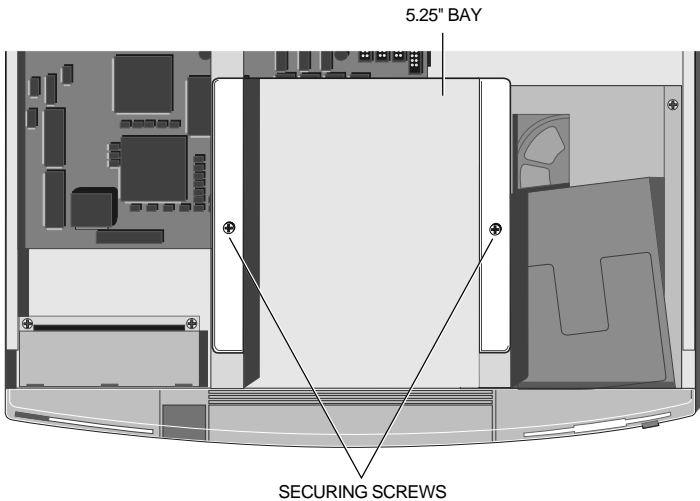

3. Remove the two screws that secure the drive bay and slide the bay backwards.
4. Lift the bay out of the system unit.
5. The aperture in the chassis at the front of the drive bay is obscured by a blanking plate. The blanking plate is attached to the top of the chassis and must be removed in order to install a drive in the 5.25" drive bay.

Open the drive bay door and identify the blanking plate.

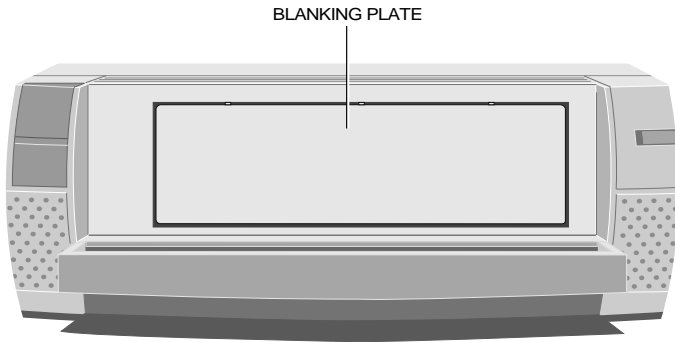

6. Break the blanking plate out by bending it backwards and returning it to the vertical several times.
7. Remove the drive from its packaging. With the drive there should be four screws and a signal cable. Some drives may be supplied with additional items.
8. If necessary configure the drive. Drives supplied by Apricot will be correctly configured for installation in a XEN.

For information on how Apricot-supplied drives are configured see the drive specific information following these installation instructions.

9. Identify the top and bottom of the drive.
10. Rest the drive, top down, on a suitable anti-static surface.

11. With the drive bay upside-down place it over the drive. Make sure that the bay and the drive are in the same orientation.

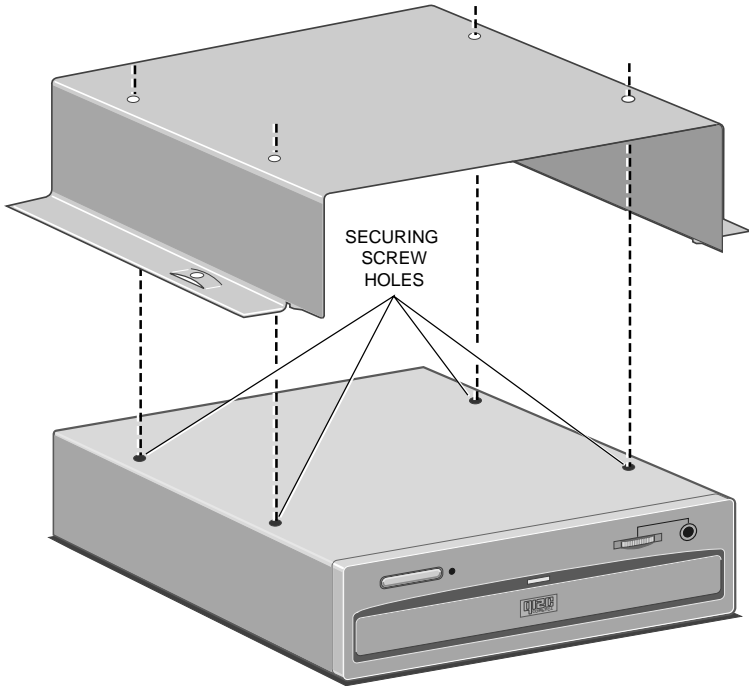

12. Line up the holes in the underside of the drive with those in the base of the drive bay.

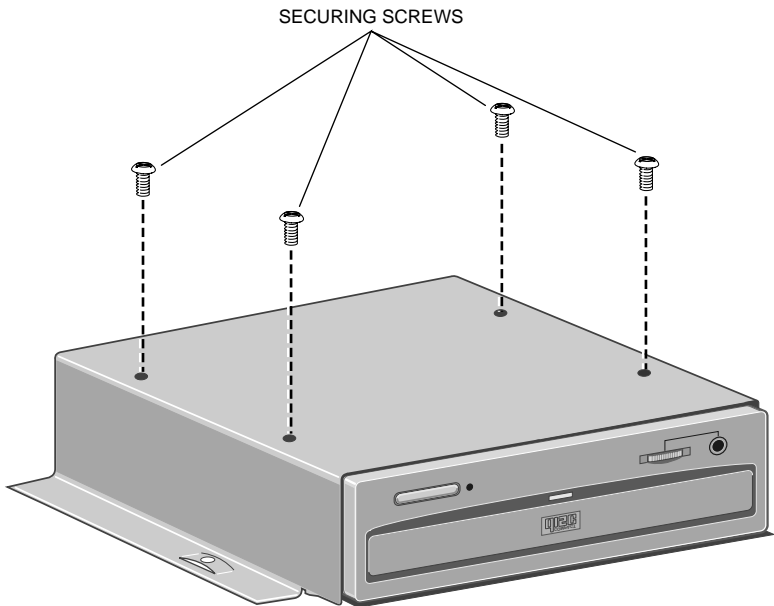

13. Insert the four drive securing screws, and tighten them until they are finger tight.
14. Gently tighten the four screws.
15. Turn the drive bay over and replace it in the system unit.
16. Slide the bay forwards until the two holes in the bay line up with those in the hard drive assembly and the system unit brace.
17. Replace the two screws that secure the drive bay.

18. Connect the spare power cable in the loom behind the drive to the drive power connector.

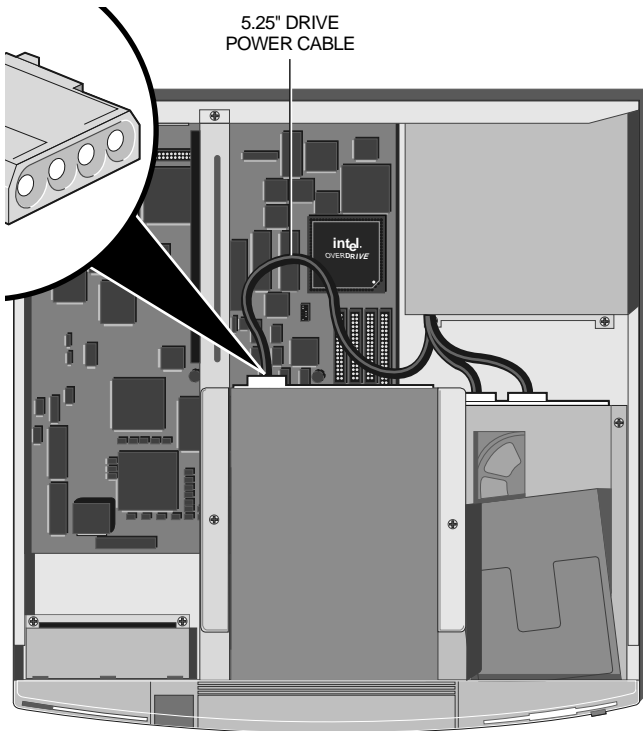

19. The drive has now been installed and connected to a power cable. You must now connect it to a signal cable. Instructions on connecting each of the types of drive to a signal cable is given under the appropriate heading overleaf.

5.25" floppy or Irwin FTD

Cabling

The 5.25" floppy and Irwin FTD drives supplied by Apricot come complete with a suitable signal cable. The signal cable must be connected between the signal connector on the rear of the drive, and the socket marked PL38 on the motherboard.

Use the label on the inside of the system unit cover to identify PL38.

Warning

Check the label on the inside of the system unit cover to make sure you are using the correct connector. Failure to do so may damage the drive or the system board.

Configuration

The only configuration on these drives is via the drive select jumpers at the rear of the drive. The jumpers should be set to drive select 1 (DS1).

SLCD CD-ROM

Cabling

The Apricot SLCD CD-ROM drive is supplied with two signal cables. The wide data cable must be connected between the rear of the SLCD CD-ROM drive and PL36 on the motherboard. The narrow audio cable must be connected between the drive and PL4 on the motherboard.

Warning

Check the label on the inside of the system unit cover to make sure you are using the correct connectors. Failure to do so may damage the drive or the system board.

The audio connector on the SLCD CD-ROM drive is identical to a 3.5" floppy drive power connector. Do not connect the spare 3.5" floppy power cable in the power supply wiring loom to the SLCD CD-ROM audio connector.

Note

If there is an expansion card installed in the bottom slot you will have to remove it in order to access PL4. PL4 is not fitted to systems without Apricot Professional Audio.

Configuration

There are no configuration options on the SLCD CD-ROM drives. DOS drivers for the SLCD CD-ROM drive are described in help files on a diskette supplied with the drive.

SCSI drives

Cabling

Apricot upgrade kits are supplied with a suitable signal cable. The cable should be connected between the SCSI card and the rear of the drive.

The following illustration shows the routing of the cable.

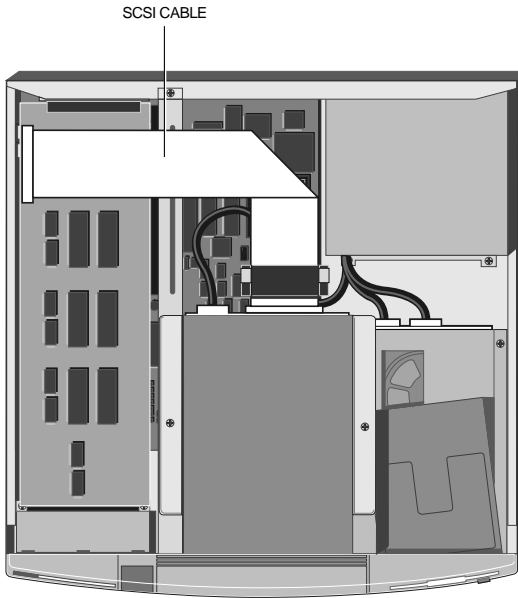

Configuration

Each SCSI drive is assigned an identity on the SCSI bus, these are known as SCSI IDs. All Apricot SCSI tape drives for XEN are supplied configured with SCSI ID 2 the SCSI CD-ROM drive is configured with ID 5.

All Apricot SCSI drives are supplied with termination resistors fitted.

3.5" hard disk drive

The XEN supports one 1.6" high or two 1" high, 3.5" hard disk drives.

Preparation

To install a hard disk drive you must first remove the 3.5" drive bay:

1. Power the system down.
2. If there is a diskette in the 3.5" floppy drive, remove it.
3. Take suitable anti-static precautions and remove the system unit cover.

If you are unfamiliar with Apricot's recommended anti-static precautions and/or the process of removing the system unit cover refer to your *Owner's Handbook*.

In order to remove the 3.5" drive bay you must first remove the 5.25" drive bay.

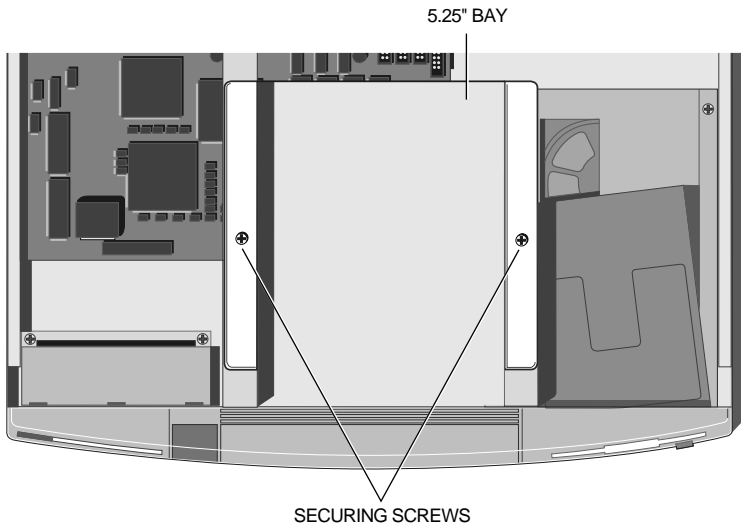

4. If there is a drive fitted in the 5.25" bay disconnect the power and signal cables from the rear of the drive.

5. Remove the two screws that secure the 5.25" drive bay and slide the bay backwards.
6. Lift the 5.25" bay out of the system unit and put it down on a safe flat surface.
7. Disconnect the cable from the rear of the 3.5" floppy drive.
8. If a 3.5" hard disk is fitted remove the signal and power cables from the rear of the drive.
9. The 3.5" drive bay is secured by two screws and two lugs in the system unit base. Identify the screws and lugs from the following illustration.

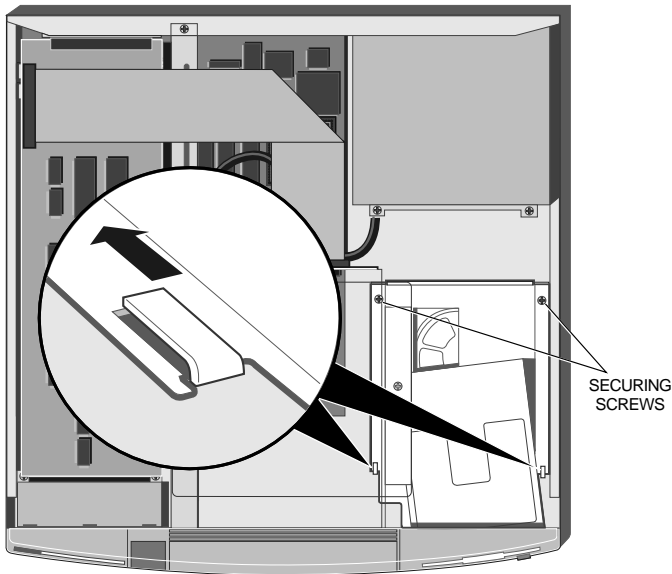

10. Remove the two securing screws shown in the illustration above.
11. Slide the 3.5" drive bay backwards and lift it out of the system unit.

Drive configuration

The XEN 3.5" drive bay supports two 1" high hard disk drives. In order for the drive or drives to operate they must be correctly configured.

The IDE interface supports a maximum of two drives. These drives are known as Master and Slave. A single drive, or the boot device in a dual drive system, must be configured as Master. The second, non-bootable, drive in a dual drive system must be configured as Slave.

IDE drives are normally configured using jumpers on the drive. Configuration details may vary from drive to drive. Apricot drives are supplied with documentation describing how to configure the drive.

If you are uncertain about configuring the drive check with your supplier.

Installing the drive

1. Having configured the drive, turn the drive bay upside-down and rest it on a flat surface with the front of the floppy drive towards you.
2. Slide the hard disk drive you are installing into the bay from the front, with the drive circuit board up, and its connectors away from you.

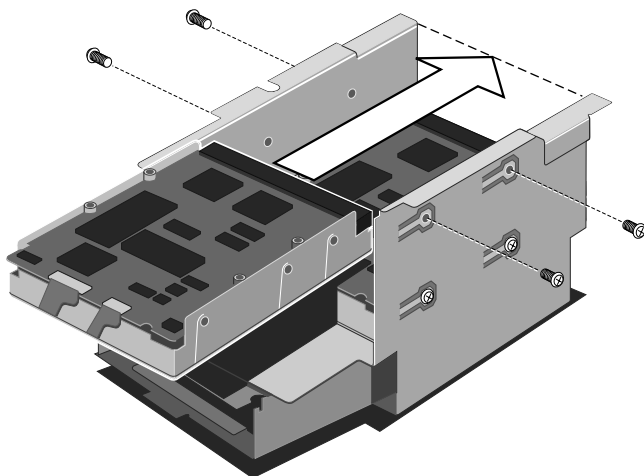

Warning

If there is a drive in the bay already, be careful to ensure that the new drive does not touch it.

Warning

It is possible to damage hard disk drives when attaching them using side mounting holes. When installing Apricot supplied hard disk drives make sure that you use the screws supplied with the drive.

When installing drives supplied by third parties, be careful to ensure that securing screws do not come into contact with drive circuit boards. If in doubt check with your supplier.

3. Line up the screw holes on the sides of the drive with those in the bay, insert the securing screws supplied with the drive and tighten them until they are finger tight.

Note

If you are installing a hard disk drive in a system that previously had only a floppy drive there will be two sets of holes available in the bay. Install the hard drive in the position closer to the floppy drive.

4. Carefully tighten the screws.
5. Turn the bay over.

Reassembling the system

1. Replace the 3.5" drive bay in the system unit. Make sure that the cutouts in the bay align with the lugs in the base of the system unit.
2. Carefully slide the 3.5" drive bay forwards. The bay is in position when the floppy drive operating button protrudes through the front bezel and the two screw holes in the bay line up with those in the base of the system unit.
3. Replace the two securing screws.
4. Connect the 3.5" hard disk(s) to their signal and power cables.
5. Reconnect the 3.5" floppy drive cable.

Warning

If the 3.5" floppy drive cable has been disconnected from the system board make sure that you reconnect it to the correct connector. Check the label on the inside of the system unit cover.

6. Replace the 5.25" bay in the system unit.
7. Slide the bay forwards until the two holes in the bay line up with those in the hard drive assembly and the system unit brace.
8. Replace the two screws which secure the 5.25" drive bay.
9. If there is a drive in the bay reconnect its power and signal cables.
10. Replace the system unit cover.

Appendix A: Configuring expansion cards

Many ISA expansion cards have a number of configurable options. These options can include items such as: the interrupt used, the DMA channel used, where any ROM on the card will appear in the processor's memory map and the address of any I/O ports used to control the card.

How to select options like this varies from card to card and will be described in documentation supplied with the card. Remember to check any floppy disks supplied with the card for README or Help files.

Most ISA cards use jumpers and/or switches to select their configuration options. If this is the case then the card should be configured before you install it. A few cards are configured using a software utility supplied with the card, this can only be done after the card is installed.

If you are not familiar with the concepts of interrupts, DMA channels, memory maps and I/O ports the following text attempts to explain what they are, and how to decide which option to select.

For the following explanations it should be understood that a peripheral can be either, a subsystem on the motherboard, or an expansion card.

Interrupts (IRQ)

The XEN (like every other ISA compatible PC) supports 15 hardware interrupts. These interrupts are used to alert the processor that a peripheral (e.g. the keyboard controller, or an expansion card) requires a particular piece of software to be executed. This piece of software is known as an *interrupt service routine*.

Each peripheral has a unique interrupt service routine that is executed in response to the interrupt assigned to that peripheral.

When an interrupt occurs the processor stops executing its current task, executes the interrupt service routine, then returns to its original task. The processor is, literally, interrupted.

A hardware interrupt may be referred to as an IRQ. This is because the motherboard signals used to generate the interrupts are labelled IRQ x where x is a number between 0 and 15, excluding 2.

Note

In an ISA compatible system if you select IRQ2 on an expansion card it uses IRQ9. This means that if an expansion card is using IRQ2, no other card can use IRQ9.

Some interrupts are assigned to standard functions and are essential for the operation of the board. Examples of these are, IRQ0 which is used to maintain the system time, and IRQ13 which is used by the coprocessor.

Selecting IRQs for cards

The table below lists the interrupts available on the motherboard and their default functions. The notes explain whether the default function can be disabled, if so how, and under what circumstances it is safe to do so.

Interrupts	Default Function	Notes
IRQ9	Not used	IRQ9 is not normally used in the XEN implementation and can be used by an expansion card.
IRQ7	Parallel port	IRQ7 is not normally used, and can be used by expansion cards without affecting the operation of the parallel port. It is possible for software to enable the parallel port's use of IRQ7. This is rare but could cause problems with a card using IRQ7. If you are not using the parallel port it can be disabled using SETUP, freeing IRQ7 to be used by an expansion card.
IRQ3 IRQ4	Serial port 2 Serial port 1	Each of the serial ports can be individually disabled using SETUP. When a port is disabled, the interrupt assigned to it is free and can be used by an expansion card. You should only disable a port if you are certain that you will not be using it.
IRQ5	SLCD interface	The SLCD interface can be disabled using SETUP if you do not have an SLCD CD-ROM drive fitted. In this case IRQ5 is available for an expansion card.
IRQ10	INA (Ethernet)	The Ethernet interface can be disabled using SETUP if you are not using the on-board Ethernet adapter to connect to a network. In this case IRQ10 is available for an expansion card.
IRQ15	Audio	The audio system can be disabled using SETUP if you are not using it. In this case IRQ15 is available for an expansion card.
IRQ14	Hard disk controller	The hard disk controller can be disabled using SETUP in a XEN which is not equipped with a hard disk. In this case IRQ14 is available for an expansion card. Warning: <i>Disabling the hard disk controller should only be contemplated on machines which are not equipped with a hard disk.</i>
IRQ1 IRQ6	Keyboard Floppy disk controller	These interrupts cannot be used by an expansion card under any circumstances.
IRQ8	Real time clock	
IRQ11	Security	
IRQ12	Mouse	

Note

In an ISA compatible system if you select IRQ2 on an expansion card it uses IRQ9. This means that if an expansion card is using IRQ2, no other card can use IRQ9.

Refer to the table above, and the documentation supplied with the card to establish which IRQ, if any, to use and how to select it.

DMA channels

ISA compatible PCs are equipped with a seven channel DMA (Direct Memory Access) controller. This DMA subsystem allows peripherals to access motherboard memory directly.

Without the DMA subsystem every memory access would have to involve the processor. Using DMA, peripherals can access memory without stopping the processor executing its current task.

The table below lists the DMA channels available on the motherboard and their default functions. The notes explain whether the default function can be disabled, if so how, and under what circumstances it is safe to do so.

DMA channel	Function	Note
0	SLCD CD-ROM interface	Available if no SLCD CD-ROM drive is fitted and the SLCD interface is disabled in SETUP
1	Audio channel A	Available if the audio system is disabled in SETUP
2	Floppy drive interface	Always used by the motherboard
3	Audio channel B	Available if the audio system is disabled in SETUP
5	not used	Available
6	not used	Available
7	not used	Available

Note

There is no DMA channel 4 on any ISA compatible system.

Refer to the table above, and the documentation supplied with the card to establish which DMA channel, if any, to use and how to select it.

Expansion card memory

Some expansion cards are fitted with ROM. Typically expansion card ROM contains extensions to the motherboard BIOS providing additional functionality.

Expansion card ROM (sometimes known as slot ROM) must be addressed somewhere in the processor's memory map. An area of the memory map of an ISA compatible PC is allocated for expansion card ROM.

If you are unfamiliar with the concept of memory maps, and the hexadecimal numbering system the following text attempts to explain them. If you are familiar with the memory map of an ISA PC then continue to *Memory configuration*.

Numbers and computers

For a variety of reasons, in computer literature and terminology, numbers are sometimes in hexadecimal notation rather than the decimal that we are all familiar with. Hexadecimal is a long word and it is often shortened to hex.

If you think of the decimal system using columns:

1000	100	10	1
(10x10x10)	(10x10)	(10)	(1)

The number 1019 is:

1000	100	10	1
1	0	1	9

Each time you add 1 to a column that contains 9 that column goes back to 0 and you add 1 to the column to the left. The columns represent powers of 10: 10x10, 10x10x10 and so on, and the decimal system is said to be *base 10*.

The hex numbering system uses a base of 16. Hex numbering works in exactly the same way as the decimal system, except you must add 1 to a column that contains 15 before you add 1 to the column to the left.

As we have no single character to represent the numbers 10 to 15, we substitute the first six letters of the alphabet, so that:

- A represents 10
- B represents 11
- C represents 12
- D represents 13
- E represents 14
- F represents 15

The example number 1019 can then be represented in hex by:

4096	256	16	1
(16x16x16)	(16x16)	(16)	(1)
0	3	F	B

We can demonstrate that 3FB is exactly the same as 1019 by:

$$(4096x0)+(256x3)+(16xF)+(1xB)=768+240+11=1019$$

Note

A lower case h is often used at the end of a number to ensure that you realise it is in hex format e.g. 3FBh.

A larger hex number and one that you will come across in the *Memory map* description below is A0000h. To see this as a decimal number:

16x16x16x16	16x16x16	16x16	16
1			
A	0	0	0
0			

$$16x16x16x16=65536$$

So A0000h is $65536x10=655360$.

If you have Microsoft Windows 3.1 on your XEN you may find it helpful to use the Windows Calculator. In Scientific View the calculator allows you to enter decimal numbers and convert them to hex, and vice versa.

Another commonly used notation is to describe numbers as xK or xM . Where $1K=1024$ and $1M=1048576$ ($1048576=1024 \times 1024$). In this notation 655360 (that is $A0000h$) is $640K$.

Memory maps

All memory, whether it is on the motherboard or an expansion card, is accessed somewhere in the processor's address space.

The processor's address space can be thought of as a list of locations, the locations are each identified by a number. The first, or bottom, location is address 0.

Every address contains 8-bits of data, a byte. Each bit can be thought of as a switch which can be either on or off. A byte is like a bank of 8-switches, where each switch can be on or off.



So 1Mbyte of memory consists of 1048576 (see *Numbers and computers*) locations each containing one byte of data.

When installing expansion cards it is the first (bottom) Mbyte of address space that is of most interest. The following diagram shows how the bottom 1M of address space is used in a XEN. Diagrams like these are called memory maps, and are a convenient way of representing processor address space.

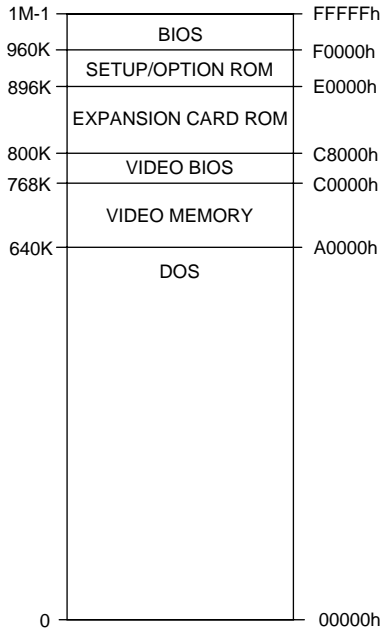

Note

The top location of this first Mbyte is 1M-1 or FFFFFh. This is because in the first Mbyte there are 1M locations, starting at 0. Location 1M is the start of the second Mbyte of address space.

The memory map above shows the uses of the first Mbyte of address space. The memory map is arranged in this way in order to be compatible with the ISA standard.

The region from 0 to 640k-1 (00000h to 9FFFFh) is used by DOS. The operating system is loaded at the bottom of this area and it uses the remainder to load applications and data.

Motherboard video adapter memory is accessed between 640k and 768k-1 (A0000h to BFFFFh). In the XEN the motherboard video BIOS is addressed between 768k and 800k-1 (C0000h to C7FFFh).

Note

This region is often used by video BIOS on expansion cards. If an expansion card with video BIOS is installed in a XEN the motherboard video must be disabled as described in Appendix B.

The region from 800k to 896k-1 (C8000h to DFFFFh) is available for expansion card ROM, other than video BIOS. While address space from 896k to 1M-1 (E0000h to FFFFFh) is used by the motherboard BIOS.

When installing expansion cards the area of most interest is between 768k and 896k-1 (C0000h to DFFFFh).

Configuring expansion ROM

Expansion card ROM is addressed in the C0000h to DFFFFh region of processor address space.

On the XEN motherboard video BIOS is accessed from C0000h to C7FFFh. If you are installing a video card it should be configured with its BIOS occupying this region and the motherboard video adapter disabled as described in Appendix B.

Note

If your video card does not allow you to configure the address range of its BIOS it will be set to the C0000h range.

The region from C8000h to DFFFFh is available for expansion card ROM other than video BIOS. It is recommended that you configure expansion card ROM at the bottom of this region, with the address ranges as close together as possible without any overlapping.

This will leave the maximum amount of memory free for use as UMB space. For information on UMB space refer to your DOS documentation, and the help files supplied with your computer.

I/O ports

I/O ports are used by the processor to control the operation of peripherals. Some expansion cards are controlled via an I/O port or group of ports.

Which port or ports the card uses can normally be selected on the card. Refer to the following table, and the documentation supplied with the card to establish which ports, if any, to use and how to select them.

Free I/O ports (Hex)
100 - 11F
128 - 1EF
202 - 2F7
324 - 387
390 - 3B3
3B6 - 3B9
3D0 - 3D3
3D6 - 3D9
3DB - 3EF
400 - 51F
528 - 917
928 - FFFF

Note

- 1. I/O ports are always given in hex notation. If you are unfamiliar with this notation refer to Numbers and computers earlier in this appendix.*
- 2. If 10-bit I/O decode is selected in SETUP only ports 0 to 3FFh can be accessed on ISA cards. To access ports from 400h to FFFFh 16-bit I/O decode must be enabled.*

Expansion Card Configuration

Slot	Card	IRQ	DMA channel	I/O ports	ROM address
1					
2					
3					

Appendix B: Motherboard video adapter

Video disable jumper

The XEN motherboard is fitted with a jumper which allows the motherboard video adapter to be disabled. If you install a video expansion card you must remove this jumper, otherwise it is unlikely that either the motherboard video adapter or the video expansion card will function correctly.

Disabling motherboard video

1. Power the system down.
2. Take suitable anti-static precautions and remove the system unit cover.

If you are unfamiliar with Apricot's recommended anti-static precautions and/or the process of removing the system unit cover refer to your *Owner's Handbook*.

3. Identify the motherboard video disable jumper. Viewing from the front of the system unit the jumper is to the right of the expansion card backplane by the rear of the backplane connector.

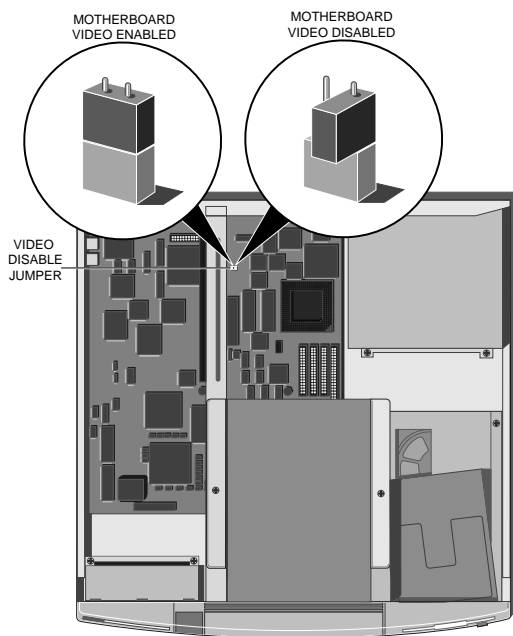

4. Remove the jumper clip from the two pin connector and replace it on only one of the connector posts as shown above.

Note

If you remove the video card you will have to return the jumper clip to its original position to enable the motherboard video adapter.

5. Replace the system unit cover.

Video feature connector

The XEN motherboard video adapter provides a video feature connector. The connector on the motherboard uses a standard pinout and a standard cable may be used to connect the feature connector to an expansion card. In case you have difficulty obtaining a cable the pinout of the motherboard connector is given in the following table.

Pin	Function	Pin	Function
1	Ground	2	P0
3	Ground	4	P1
5	Ground	6	P2
7	-EVIDEO	8	P3
9	-ESYNC	10	P4
11	-EDCLK	12	P5
13	No connect	14	P6
15	Ground	16	P7
17	Ground	18	DCLK
19	Ground	20	-BLNK
21	Ground	22	HSYNC
23	Ground	24	VSYNC
25	No connect	26	Ground

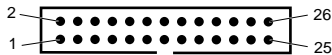

Appendix C:

Approved SIMMs

The Apricot XEN system board uses standard gold plated 4, 8 or 16 Mbyte 36 bit, 70nS SIMMs. The following list identifies the SIMMs that have been tested and approved for use in XEN by Apricot.

Description	Vendor	Part No.
4 Mbyte (1MX36)	Fujitsu	MB85346A-70
	Goldstar	GMM7361000SG-70
	Micron	MT12D136G-7
	Mitsubishi	MH1M36EJ-7
	NEC	MC421000A36FH-70
	NEC	MC421000A36FJ-70
	Samsung	KMM5361000BG-6
Samsung	KMM5361000BG-7	
8 Mbyte (2MX36)	Fujitsu	MB85347A-70
	Goldstar	GMM7362000SG-70
	Micron	MT24D236G-7
	Mitsubishi	MH2M36EJ-7
	NEC	MC422000A36FH-70
	NEC	MC422000A36FJ-70
	Samsung	KMM5362000BG-7
Toshiba	THM362020ASG-70	
16 Mbyte (4MX36)	Hitachi	HB56D436B7
	NEC	MC424000A36FH-70
	Toshiba	THM364020SG-60

The XEN 32Mbyte SIMM is a proprietary part that can only be obtained from Apricot.

Warning

SIMMs not included in the list above cannot be guaranteed to operate correctly in the XEN.

apricot

APRICOT COMPUTERS LIMITED
3500 PARKSIDE
BIRMINGHAM BUSINESS PARK
BIRMINGHAM B37 7YS.

 MITSUBISHI ELECTRIC