

apricot



LOC Technology, KeyLOC and Integrated Network Architecture are trademarks of Apricot Computers Limited.

Crystal and CrystalWare are trademarks of Crystal Semiconductor Corporation.

AMD and PCnet are trademarks of Advanced Micro Devices.

Microsoft and MS-DOS are registered trademarks, and Windows and Windows NT are trademarks, of Microsoft Corporation.

Intel is a registered trademark, and Intel486, IntelDX4, Pentium and OverDrive are trademarks, of Intel Corporation.

PC Card is a trademark of the Personal Computer Memory Card International Association.

Phoenix is a registered trademark of Phoenix Technologies Ltd.

Ad Lib is a registered trademark of Ad Lib Inc.

Information contained in this document is subject to change without notice and does not represent a commitment on the part of Apricot Computers Limited. Any software described in this manual is furnished under a license agreement. The software may be used or copied only in accordance with the terms of this agreement. It is against the law to copy any disk supplied for any purpose other than the purchaser's personal use.

All rights reserved; no use or disclosure without written consent.

Copyright © Apricot Computers Limited 1994

Published by  
Apricot Computers Limited  
3500 Parkside  
Birmingham Business Park  
Birmingham B37 7YS

 MITSUBISHI ELECTRIC

Printed in the United Kingdom

Part No. 15289131

Revision 02

## ***Safety and Regulatory Notices***

---

Read the separate *Power Connection Guide* before using the computer for the first time. Information in the *Owner's Handbook* relating to connection to the AC power supply may not apply outside the United Kingdom.

The computer uses a safety ground and must be earthed. The system unit AC power cord is its “disconnect device”. Ensure that the system unit is positioned close to the AC power outlet, and that the plug is easily accessible.

It is imperative that the system unit is set to the correct voltage range before use. If not, the machine may be irreparably damaged.

To prevent fire and electric shock, do not expose any part of the computer to rain or moisture.

Turn off the computer and unplug all power cords before moving the system unit, cleaning the computer or removing the system unit top cover.



When positioning the system unit, monitor and keyboard, take into account any local or national regulations relating to ergonomic requirements.

Microphone and headphone cables must be less than 2 metres long.

### ***Power cord requirements***

The power cord packed with the computer complies with the safety standards applicable in the country in which it is first sold. Use only this power cord; do not substitute a power cord from any other equipment.

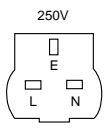
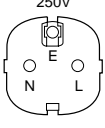
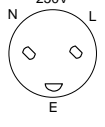
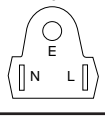
If you wish to use the computer in another country, you must ensure that you use a power cord and plug which complies with the safety standards of that country.

Plug	Standard	Countries
250V 	BSI363A	United Kingdom
250V 	SHUCO	Austria, Belgium, Finland, France, Germany, Holland, Italy, Norway, Sweden
250V 	SRAF 1962/ DB16/87	Denmark
125V 	NEMA 5-15P	USA, Canada
250V 	ASE 1011	Switzerland
250V 	AS 3112-1981	Australia

The power cord fittings must bear the certification mark of the agency responsible for evaluation.

Refer to your supplier if you ever require additional or alternative power cables.

**UK plug wiring instructions**

**IMPORTANT:  
Power Cable  
Connections**

This equipment is supplied with a mains lead that has a non-removable moulded plug. If the socket outlets are not suitable for the plug supplied with this appliance, it should be cut off and an appropriate three-pin plug fitted.

**Note:** The plug severed from the mains lead must be destroyed, as a plug with the bared flexible cord is hazardous if engaged in a live socket outlet.

The following wiring information should be employed when adding the replacement plug.

The wires in the mains lead are coloured in accordance with the following code:

Green and Yellow	Earth
Blue	Neutral
Brown	Live

As the colours of the wires in the mains lead of this appliance may not correspond with the coloured markings identifying the terminals in your plug, proceed as follows.

The wire which is coloured green-and-yellow must be connected to the terminal in the plug which is marked with the letter **E**, or by the earth symbol  $\equiv$  or coloured green or green-and-yellow.

The wire which is coloured blue must be connected to the terminal which is marked with the letter **N** or coloured black. The wire which is coloured brown must be connected to the terminal which is marked with the letter **L** or coloured red.

Use a fuse approved to BS1362, i.e. one which carries the  $\diamond$  or  $\heartsuit$  mark. Only replace the fuse with one of the same type and rating.

Always replace the fuse cover, never use the plug with the fuse cover omitted.

Replace with same colour fuse cover only. Replacement fuse covers may be obtained from your dealer.

**WARNING: THIS APPLIANCE  
MUST BE EARTHED**

This diagram shows the wiring inside the moulded plug. Use it as a guideline if you need to re-fit a plug of a similar type to the mains lead.

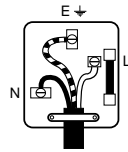

**Noise levels**

*German Acoustic Noise Regulation*

Sound power level is less than 70 dB(A) according to DIN 45635 Part 19 (ISO 7779).

Refer to the labels on the underside of the computer to establish which of the following warnings apply.

## **FCC Class A**

**Warning** - this equipment has been tested and found to comply with the limits for a Class A computing device, pursuant to Subpart J of Part 15 of FCC rules. Only peripherals (computer input/output devices, terminals, printer, etc.) certified to comply with the Class A limits may be attached to this computer. Operation of this equipment in a residential area may cause unacceptable interference to radio and television reception requiring the operator to take whatever steps are necessary to correct the interference.

## **FCC Class B**

**Warning** - this equipment has been certified to comply with the limits for a Class B computing device, pursuant to Subpart J of Part 15 of FCC rules. Only peripherals (computer input/output devices, terminals, printer, etc.) certified to comply with the Class B limits may be attached to this computer. Operation with non-certified peripherals is likely to result in interference with radio and TV reception.

### *Radio and television interference*

The computer described in this manual generates and uses radio frequency energy for its operation. If it is not installed and used properly, in strict accordance with the manual, it may cause interference with radio and television reception.

The computer has been tested and found to comply with the RF emission limits for an FCC Class B computing device which is intended to provide reasonable protection against such interference in a residential installation. However, there is no guarantee that interference will not occur in a particular installation.

If this equipment does cause interference with radio or television reception, which can be determined by turning the equipment off and on, the user is encouraged to try to correct the interference by one or more of the following measures:

- Move the computer away from the receiver being interfered with.
- Turn the computer with respect to the receiver.
- Turn the receiver with respect to the computer.
- Plug the computer into an outlet that is on a different branch circuit from the receiver.
- Disconnect and remove any I/O cables that are not being used.
- Unplug and remove any expansion cards that are not being used, and replace the relevant blanking plates.
- Make sure that the computer is plugged into a grounded outlet.

If you need additional help, consult your supplier. You may find the following booklet helpful: How to Identify and Resolve Radio-TV Interference Problems. This booklet is available from the US Government Printing Office: Washington DC 20402 - Stock No. 004-000-000345-4.

## **DOC Class A**

The computer described in this manual complies with: Canadian DOC radio interference regulations CRCc 1374 governing Class A digital devices.

## **DOC Class B**

The computer described in this manual complies with: Canadian DOC radio interference regulations CRCc 1374 governing Class B digital devices.





# CONTENTS

## **1**      ***Introducing...***

---

Summary of features 1/1  
Unpacking 1/3  
Pictorial guide 1/6

## **2**      ***Getting Started***

---

General advice 2/1  
Connecting the components 2/2  
Turning on and booting the computer 2/4  
Backing up pre-installed software 2/9  
Using the 3.5" diskette drive 2/10  
Using the BIOS Setup utility 2/12  
Using Apricot Help 2/13

## **3**      ***Using the BIOS Setup Utility***

---

Accessing BIOS Setup 3/1  
Using BIOS Setup dialogs 3/2  
Basic configuration options 3/4  
Advanced configuration options 3/9

## **4**      ***Networking***

---

What is Integrated Network Architecture? 4/1  
Finding out about your network 4/2  
Selecting thick- or thin-Ethernet 4/3  
Connecting Ethernet cables 4/3

## **5**      ***Using the Audio System***

---

Connecting audio devices and controlling output volume 5/1  
Using the audio system under Microsoft Windows 5/4  
Using the audio system under MS-DOS 5/4

## **6**                    **Using the Security System**

---

- Features of the security system 6/1
- Configuring the security system 6/4
- Setting up a security configuration 6/6
- Defining user accounts 6/9
- Understanding the logon sequence 6/14
- Changing a password at logon 6/17
- Unattended mode for Microsoft Windows 6/18
- Telling users about the security system 6/19

## **7**                    **Using PCMCIA Cards**

---

- What is PCMCIA? 7/1
- Installing PCMCIA cards 7/2
- Inserting and removing PCMCIA cards 7/2
- Configuring PCMCIA cards 7/4

## **8**                    **Maintaining and Transporting**

---

- Cleaning the computer 8/1
- Recharging the configuration battery 8/3
- Transporting the computer 8/4
- Using the computer in another country 8/4

## **9**                    **Upgrading**

---

- Adding more memory 9/2
- Upgrading the processor 9/5
- Adding an external cache 9/9
- Adding a diskette drive 9/10
- Adding a hard disk drive 9/13
- Adding both drives at once 9/15

## **A**                    **Inside the System Unit**

---

- Anti-static precautions A/1
- Opening the system unit A/2
- Changing jumper settings A/3

**B**                    **Technical Information**

---

- Specifications B/1
- Physical characteristics B/2
- Electrical characteristics B/2
- Port characteristics B/3
- System resources B/8

**C**                    **Quick Guide To Security**

---



# INTRODUCING

This chapter gives you a quick tour of your Apricot LS Pro computer. The initial summary of features is intended mostly for people who know a bit about computers and want to get an idea of what this one can do. But the unpacking instructions and pictorial guide will be helpful to everyone.

Don't worry if you're unfamiliar with some of the computer terminology used in this chapter. It's provided simply as a useful "shorthand" for more experienced readers. Be assured, you don't need to understand any jargon to use the Apricot LS Pro safely and efficiently. (On the other hand, it can't hurt to learn; introductory books about computers can be found in your local bookshop or library.)

---

**Warning**

*Read the separate Power Connection Guide before using the computer for the first time.*

---

---

## Summary of features

---

### Standard features

The standard features of the Apricot LS Pro range include:

- Intel486 or IntelDX4 system processor with Pentium OverDrive upgrade capability.
- 4 Mbytes of motherboard memory, upgradable to 64 Mbytes by the use of standard SIMMs (single in-line memory modules).
- Graphical BIOS Setup configuration utility in read-only memory (ROM).
- Cirrus Logic CL-GD543x/VL VESA local bus Enhanced Video Graphics Array (EVGA) controller with at least 1 Mbyte of video memory.

- Integrated Network Architecture™ (INA): Advanced Micro Devices PCnet-32 VESA local bus Ethernet adapter with ports for thick, thin and twisted-pair Ethernet, and RPL (Remote Program Load) support in BIOS.
- Enhanced Business Audio system: based on a Crystal Semiconductor CS4231 chipset (featuring 16-bit digital audio, stereo analog mixer and an Ad Lib-compatible FM synthesizer), with stereo input/output sockets and master volume control.
- Apricot LOC Technology™ v2.0 proprietary ROM-based on-board security system.
- PCMCIA module with Type II and Type III PC Card sockets. Supports “Plug and Play” (PnP) interface.
- Integrated Drive Electronics (IDE) disk drive system (various capacities) and a 1.44 Mbyte 3.5" diskette drive (optional).
- Parallel port with standard or ECP/EPP (Extended Capabilities Port/Enhanced Parallel Port) functionality; dual-channel serial port; extended keyboard; two-button mouse.

### **Energy-efficient features**

Most models in the range comply with the requirements of the US Environmental Protection Agency’s “Energy Star” programme for energy-efficient computers. These models support:

- System Management Mode (SMM) of Intel SL Enhanced processors.
- VESA BIOS Extensions for Power Management (VBE/PM), for use with energy-efficient monitors that support Display Power Management Signalling (DPMS).

Models fitted with very-high-capacity hard disk drives may be unable to comply with Energy Star. Ask your supplier for more information.

## Advanced features

The following advanced features are available on some models in the range:

- 256 Kbyte external (second-level) memory cache.
- 2 Mbytes of video memory (offering, for example, 800x600 resolution in 24-bit or true colour).

## Unpacking

---

On unpacking the computer, you should find:

- Apricot LS Pro system unit.
- Apricot/Mitsubishi monitor and accompanying *User's Guide*.
- Apricot extended keyboard, two-button mouse and mono microphone.
- System unit AC power cord and monitor power cord appropriate for the country of sale.
- System documentation (this *Owner's Handbook*, etc.)
- Microsoft MS-DOS pack.
- Microsoft Windows for Workgroups pack (if the system has a hard disk).

More elaborate systems may include software or hardware options with accompanying installation diskettes and additional documentation. Some of these options may have been factory-configured or installed by your supplier.

Keep the cartons, boxes and packaging materials; you will need them again if you have to transport the computer elsewhere.



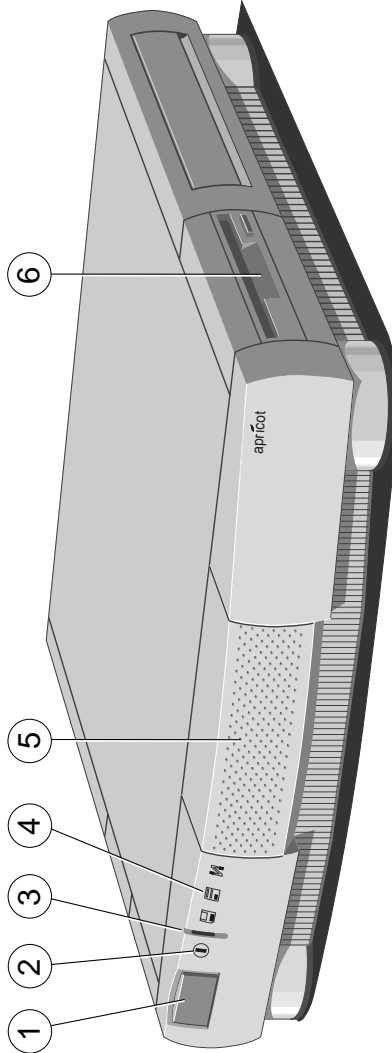

Make a note of the manufacturer's data recorded on the various components (product codes, serial numbers, etc.). A service engineer may need this information if the computer develops a fault.

## Pictorial guide

---





- ① **Power button:** press to turn the system on or off.
- ② **power indicator:**  lights when the system unit is powered.
- ③ **infrared sensor:** detects the coded signals produced by a KeyLOC card (an optional hand-held infrared device that can be used with the security system).
- ④ **activity indicators, from left to right:**
  -  lights when the diskette drive is in use
  -  lights when the hard disk is in use (depending on the operating system)
  -  lights when the computer accesses the network (depending on the network software)
- ⑤ **speaker grille.**
- ⑥ **3.5" diskette drive** (optional).

There are **air vents** along the front and right-hand sides of the system unit; do not block these vents or the system will overheat.

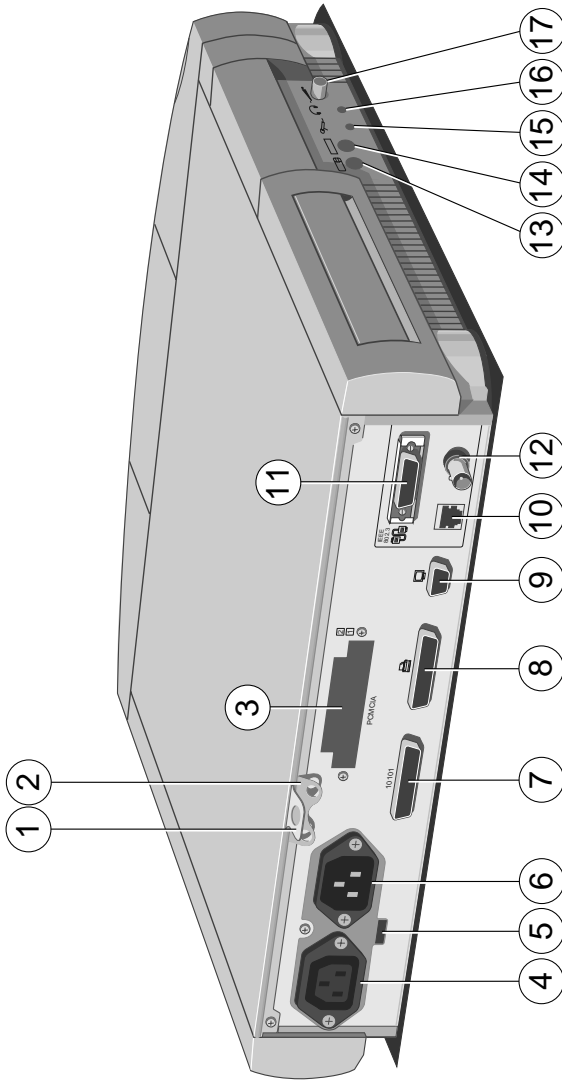

- ① **security loop:** you can put a padlock through this loop to secure the top cover.
- ② **handle:** to remove the top cover, remove the retaining screws at each side, then grasp and pull this handle firmly.
- ③ **PCMCIA slots:** suitable for all types of Personal Computer Memory Card International Association (PCMCIA) PC Card devices.
- ④ **AC power outlet:** where the monitor power cord can plug in.
- ⑤ **voltage selection switch:** the system unit can be set to operate with a 100-120 volt or 220-240 volt AC power supply.
- ⑥ **AC power inlet:** where the system unit power cord plugs in.
- ⑦ **dual-channel serial port** (50 baud to 19,200 baud): typically used for connecting an external modem or a serial printer signal cable.
- ⑧ **parallel port:** typically used for a printer signal cable.
- ⑨ **monitor port:** connect the monitor signal cable to this port.
- ⑩ **TPE Ethernet port:** connect a cable with an RJ-45 connector to this port, to link the computer into a twisted-pair Ethernet (10Base-T) network.
- ⑪ **AUI Ethernet port** (optional): connect an attachment unit interface transceiver “drop” cable to this port, to link the computer into a thick-Ethernet (10Base-5) network.
- ⑫ **BNC Ethernet port:** connect a BNC T-connector to this port, to link the computer into a thin-Ethernet (10Base-2) network.
- ⑬ **mouse port:** connect the mouse to this port.
- ⑭ **keyboard port:** connect the keyboard to this port.

- ⑮ **audio input socket:** allows you to connect a microphone, a personal stereo (tape or CD), or a stereo line-in signal from a high-fidelity tape deck or CD player, to be used as a recording or monitoring source.
- ⑯ **audio output socket:** allows you to connect a stereo headset or a pair of self-powered speakers. Alternatively, it can provide a stereo line-out signal to a high-fidelity amplifier or tape deck.
- ⑰ **volume control:** a rotary control that adjusts the volume of sound through the internal speaker and the audio output socket.

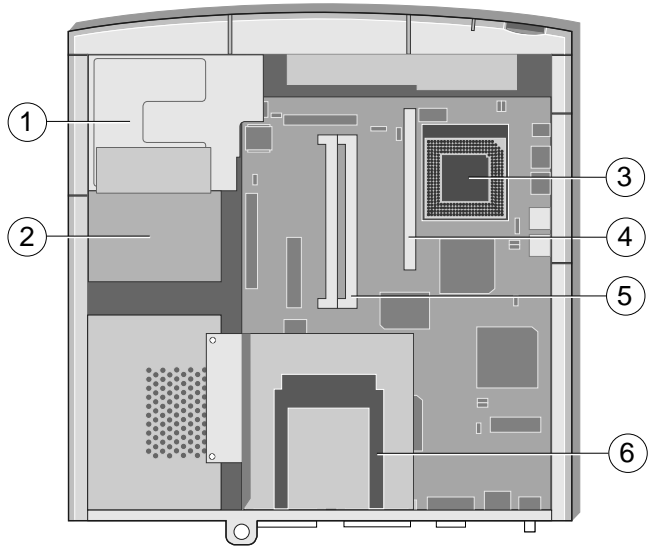

- ① **3.5" diskette drive** (optional).
- ② **1" hard disk drive** (optional).
- ③ **ZIF (zero insertion force) processor socket:** the current system processor can be replaced by a higher performance processor.
- ④ **cache socket:** a 256 kilobyte (Kbyte) external memory cache can be added if not already present.
- ⑤ **SIMM sockets:** the computer's base 4 megabytes of motherboard memory can be upgraded to 64 megabytes by the use of single in-line memory modules (SIMMs).
- ⑥ **PCMCIA module:** PCMCIA PC Card devices offer a wide range of expansion options such as fax/modem, Token-Ring adapter or removable hard drives.

See the **label** on the inside of the system unit lid for up-to-date information about the layout of the motherboard.



## 2

# GETTING STARTED

You should read this chapter even if you do not read any other. It provides important information to help you site, connect, power and configure the computer.

This chapter will tell you all you need to know in order to start work. The chapters after this one deal with the special features of the computer: BIOS Setup, networking, audio and security.

---

### **Warning**

*Read the separate Power Connection Guide before using the computer for the first time.*

---

### **General advice**

---

This computer is designed to be used in a normal office environment. Here are a few hints for choosing a suitable site:

- Place the system unit flat on a sturdy, level surface. Remember to allow enough room on the right for you to use the diskette drive, if one is fitted.
- Site the computer away from moisture, direct sunlight, and extremes of heat and cold. Avoid situations in which the surrounding temperature or humidity may change rapidly.

See Appendix B, “Technical Information”, for recommended temperature and humidity ranges.

- When positioning the system unit, monitor and keyboard, take into account any local or national regulations relating to ergonomic requirements.

For example, you should ensure that as little ambient light as possible is reflected off the monitor screen as glare, and that the keyboard is placed in a comfortable position for typing.

- Give the computer plenty of room so that air can circulate on all sides. Air is drawn into the system unit through the vent under the front bezel and expelled through a vent on the right-hand side. Ensure that these vents are never obstructed.
- Do not allow any cables, particularly power cords, to trail across the floor where they can be snagged by people walking past.

---

**Warning**

*The computer uses the system unit AC power cord as its “disconnect device”. Ensure that the system unit is positioned close to the AC power outlet, and that the plug is easily accessible.*

*To prevent fire and electric shock, do not expose any part of the computer to rain or moisture.*

---

## **Connecting the components**

---

See Chapter 1, “Introducing...”, if you need help identifying the various ports on the system unit.

### **Checking the AC power supply**

When your computer is delivered, it is ready for the commercial AC power supply generally available in the country in which it is first sold. It has been set for the correct voltage range, and is supplied with an AC power cord and plug which comply with the relevant safety standards.

Before using the computer in a country *other than that in which it was originally sold*, you must discover the voltage and frequency of that country’s AC power supply, and the type of power cord required there. Check the power rating labels on the rear of the computer’s system unit and its monitor to ensure that they are compatible with the AC power supply.

If necessary, the AC voltage setting of the system unit can be adjusted by the voltage selection switch on the rear of the system unit. Refer to Chapter 8, “Maintaining and



Transporting”, for instructions on how to do this. It is likely that the monitor’s voltage setting will also need adjusting; consult the *User’s Guide* that accompanies the monitor, or ask your supplier for help.

The “Safety and Regulatory Notices” section at the start of this *Owner’s Handbook* includes advice about suitable power cords.

### **Installing add-on options**

If your computer arrived with uninstalled add-on options, (such memory modules) consult Chapter 9, “Upgrading”, for step-by-step instructions for installing them. Some items may have their own documentation that supplements or overrides the instructions in this manual.

### **Connecting the components**

Having assured yourself that the voltage settings and the AC power cords of the computer, the monitor and any other peripherals are correct, use the procedure below to connect these components together. It is important that you take each step the in order indicated.

1. If your AC power outlets have switches, set them to their Off positions.
2. Ensure that the system unit, the monitor, and any peripherals are turned off.
3. Connect the monitor signal cable between the monitor and the monitor port on the rear of the system unit.

If the monitor signal cable is connected *after* the computer is turned on, the display may appear in monochrome (or not at all).

4. Where appropriate, connect other signal cables between your peripherals and their respective ports on the system unit. Make sure the signal cables are connected securely.
5. Plug the keyboard cable into the keyboard port on the system unit. Be careful not to plug it into the mouse port by mistake.

6. Plug the mouse into the mouse port on the system unit.  
Never connect either the keyboard or the mouse while the system unit is turned on.
7. Where appropriate, connect the computer to the network. See Chapter 4, “Networking”, for guidance on connecting the computer to Ethernet networks.
8. Connect the monitor power cord between the monitor and the AC power outlet on the rear of the system unit.
9. Connect the system unit power cord between the AC power inlet on the rear of the system unit and a nearby, grounded AC power outlet.
10. Where appropriate, connect power cords between your peripherals and nearby, grounded AC power outlets.
11. If your AC power outlets have switches, set them to their On positions.

The computer is now ready to use. The rest of this chapter tells you how to turn the computer on and off, and how to configure it using the BIOS Setup utility.

## ***Turning on and booting the computer***

---

### ***Turning the power on***

To turn on the computer, simply press the POWER button. The green indicator next to the POWER button lights to show that the system unit is powered. Remember that the monitor has its own power control; see the monitor’s *User’s Guide* for details.

If the computer does not start when the POWER button is pressed, check that the system unit and monitor power cords are securely connected and that the AC power supply is switched on.

In the United Kingdom, and some other countries, AC plugs contain fuses. If the fuse in the system unit’s AC plug blows when you turn it on, this may be caused by an AC power surge,

but is more often a symptom of problems with the computer or its peripherals. Follow these steps:

1. Turn off the computer and unplug all power cords.
2. Unplug all peripherals.
3. Try to discover the cause of the fault. If none is apparent, replace the blown fuse with one of the same rating, reconnect the system unit power cord and try to turn it on again.
4. If the replacement fuse blows, call an authorized maintainer.

If the replacement fuse does not blow, reconnect a peripheral and turn it on. Repeat this step for each peripheral in turn.

---

**Caution**

*Always make sure that the system unit is turned on **before** turning on any attached peripherals, particularly a printer attached to the parallel port. The parallel port is vulnerable to surges in the AC power supply which may be passed on by the printer's signal cable.*

---

**Power-on self-test**

Whenever the computer is turned on, the power-on self-test (POST) routine tests various hardware components, including memory, and compares the actual configuration of the computer with that recorded in its memory. During this time, various sign-on and POST messages are displayed, and you have the opportunity of invoking the BIOS Setup utility to reconfigure the computer (described later in this chapter). The appearance of the screen during POST depends on whether you have chosen the Text or Graphics startup option with BIOS Setup.

A configuration discrepancy might arise if you have just installed or removed a hardware option (for example, if you have added or replaced a SIMM). In this case the BIOS Setup utility is started automatically.

If POST detects a hardware fault, one or more error messages are displayed. You may also be prompted to “Press the F1 key to continue.” Your first action should be to turn off the computer, wait at least 30 seconds, and then turn it on again to see if the error is transient or persistent. Persistent POST errors may indicate a fault in your system. If you press F1, the computer attempts to continue despite the error indication (for example, if a memory chip fails POST, the computer can continue with less memory). If the problem persists, make a note of the error messages, and consult your supplier or authorized maintainer.

### **Beep codes**

The computer uses special audio beep codes to signal certain hardware faults. If you hear a beep code which is not accompanied by a POST error message, call your supplier or authorized maintainer.

## **The boot sequence**

Provided that POST succeeds without discovering any serious errors or configuration discrepancies, the computer attempts to find an operating system; that is, it attempts to *boot*. There are three possibilities it may try: a system diskette, a bootable hard disk partition, or remote booting.

### **System diskette**

A system diskette is a diskette bearing at least the rudiments of an operating system. If the computer finds such a diskette in the diskette drive, it will boot from it. If it finds a non-system diskette, the computer invites you to replace it and press the F1 key.

The BIOS Setup utility can be used to disable booting from a system diskette.

### **Hard disk partition**

The computer will try its hard disk if it can't find a system diskette. A hard disk may contain more than one bootable

partition, for different operating systems, but only one of these can be active at any one time. The computer loads its operating system from the currently active partition.

Computers with a hard disk normally arrive with the Microsoft MS-DOS/Windows operating system already in place or *pre-installed*.

If necessary, your operating system manuals should tell you how to format a blank diskette as a system diskette or how to partition and format a hard disk.

---

**Caution**

*Partitioning or formatting a hard disk erases all the programs and data recorded on that disk. Always make a backup copy of the contents of the hard disk before you start.*

---

**Remote booting**

Remote or network booting means that the computer loads its operating system from a server elsewhere on the network. The computer has a built-in ability to do this, by virtue of the Remote Program Load (RPL) code in its BIOS ROM.

You have to enable RPL (pronounced “ripple”) with the BIOS Setup utility. If your computer has a diskette or hard disk drive, you will be asked each time the computer boots whether or not you want to boot remotely this time.

Remote booting won’t work unless there’s a RPL server somewhere in your network. Don’t attempt to boot your computer in this way without first checking with the network administrator.

The following table lists some of the messages that might appear during the boot sequence.

Message	Explanation
Non-system disk or disk error	The diskette drive contains a non-system diskette. Replace it with a system diskette and press F1.
Diskette read failure	The diskette is either not formatted or defective. Replace it with a system diskette and press F1.
No boot sector on fixed disk	The hard disk has no active, bootable partition or is not formatted. Insert a system diskette, press F1, and format the hard disk as described in your operating system manuals.
Fixed disk read failure	The hard disk may be defective. Press F1 to retry. If the problem persists, insert a system diskette, press F1, back-up the data held on the defective hard disk and try reformatting it.
No boot device available	This may indicate a fault in the diskette or hard disk drive, or perhaps a damaged system diskette. Press F1 to retry, using another system diskette if possible. If the problem persists, consult your supplier or an authorized maintainer.

### Turning the power off

Before turning off the computer, run through the following checklist:

1. Quit or exit from the applications you are running; be sure to save any files you have altered.

Any unsaved information still held in the computer's system memory will be lost when you turn off the computer.

2. If you are logged-in to a network, logout before turning off your computer.  
This gives the network operating system a chance to free up the network resources you've been using.
3. Close down or quit any software that employs virtual memory or disk-caching (for example, Microsoft Windows with SMARTDrive).
4. Turn off any attached peripherals first, especially any peripheral attached to the parallel port. However, there's no need to turn off the monitor if it's being powered from the system unit.
5. Wait until all the activity indicators on the front bezel are unlit.

To turn off the computer, simply press the POWER button again. The power indicator on the front bezel goes out. If the monitor is powered from the system unit, it will be turned off at the same time.

After you turn the computer off, wait at least 5 seconds before turning it on again. The computer may not initialize itself properly if you turn it off then on again in quick succession.

## ***Backing-up pre-installed software***

---

Computers with a hard disk normally arrive with the Microsoft MS-DOS/Windows operating system pre-installed. Additional software may be pre-installed by your supplier.

We recommend that you copy or *back up* any pre-installed software soon after setting up your system. This is particularly important for systems which are supplied without installation diskettes for the software on the hard disk. A backup copy will safeguard the pre-installed software against loss if the hard disk fails or if you accidentally overwrite or delete files.

A disk imaging utility is included with all pre-installations of Windows. This allows you to create installation diskettes from

disk images present on the hard disk. Once you have done this, you can delete the disk images from your hard disk. See the utility's on-line help for more information.

To back up other pre-installed software, use Backup for DOS or Backup for Windows as described in your MS-DOS manual. It is a good idea to begin by creating a bootable system diskette containing the programs needed to partition and format the hard disk and to restore the backed up copy. In this way, you should be able to recover any programs or data lost by a hard disk failure.

---

**Note**

*Any copy you make of pre-installed software must be used only as a backup copy, in case the pre-installed version is lost or needs re-installing or reconfiguring. In particular, you are **not** allowed to use installation diskettes created from disk images to install the software onto another computer.*

---

## **Using the 3.5" diskette drive**

---

The (optional) 3.5" diskette drive can read and write double-sided diskettes with a formatted capacity of either 1.44 Mbytes (if marked "HD" or "high density") or 720 Kbytes (if marked "DD" or "double density").

Each diskette has a rigid plastic cover with a metal shutter that guards the disk surface. The drive automatically moves the shutter aside to read the diskette. Never touch the exposed surface under the shutter; you could deform the disk or leave a fingerprint that might make the diskette difficult to read.

Keep diskettes well away from dust, moisture, magnetic objects, and equipment that generates magnetic fields. Also, avoid extremes of temperature and exposure to direct sunlight. Otherwise, data recorded on the diskette may become corrupted.



### **Inserting a diskette**

A diskette is inserted into the diskette drive slot shutter-foremost, and with its label side facing up (see diagram). To help you check the diskette is the right way round, there's usually a small arrow on the face of the diskette which must point towards the drive when you insert it.

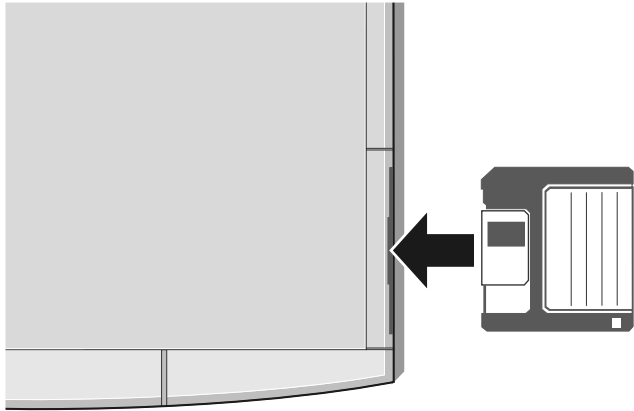

Push the diskette all the way in until it engages with the drive mechanism. When the drive's eject button pops out, the diskette is fully engaged.

### **Removing a diskette**

Before attempting to remove a diskette, make sure that the drive is not currently in use (the diskette activity indicator on the computer's front bezel must be unlit).

Press the eject button on the drive. The drive mechanism disengages and the diskette is ejected half-way out of the drive.

If a diskette becomes stuck in the drive, perhaps because its label has peeled back, do **not** attempt to remove it with tweezers or any similar implement; you risk damaging the drive. Call an authorized maintainer.

### Write-protecting a diskette

A diskette can be write-protected by sliding a small tab towards the edge of the diskette to expose the little hole beneath it (see diagram). With the tab in this position, you can read, copy or print files from the diskette, but you cannot create, rename or delete any files.

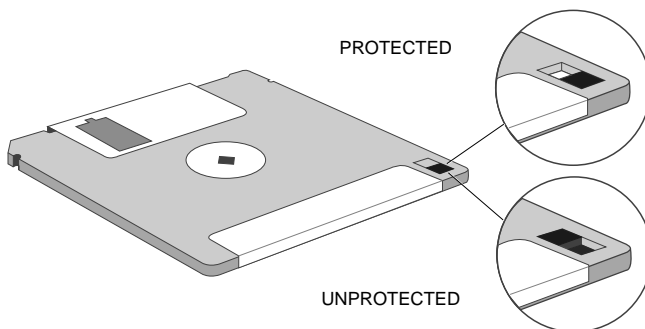

The BIOS Setup utility can disable the diskette drive, or make it read-only.

## Using the BIOS Setup utility

---

### What is BIOS?

BIOS (pronounced “bye-oss”) stands for *basic input/output system*. The BIOS operates at the boundary between the computer’s hardware (the system processor, memory, diskette and hard disk drives, and so on) and its software (the operating system and applications), and effectively mediates between the two. The BIOS is permanently encoded in an area of read-only memory (ROM), although it can be modified if necessary by an authorized maintainer.

### What is BIOS Setup?

BIOS Setup is a utility programmed into the computer’s BIOS ROM. Its main purpose is to allow you to view and alter your computer’s configuration. BIOS Setup is also used to configure the on-board security system.

To configure (set up) a computer means to declare or describe its hardware components and to say how you want them to behave. Configuring your computer is necessary to ensure that the software you use can recognise and exploit the hardware's capabilities.

A record of the current configuration is kept in a special part of the computer's memory, known as CMOS memory. This type of memory is easily sustained by a small battery, so that its contents can be preserved while the computer is turned off.

Your computer arrives already configured, but may need to be configured again if you add upgrades such as memory modules or an external memory cache.

### **Accessing BIOS Setup**

BIOS Setup can be invoked whenever you turn on or reboot your computer, by pressing the ALT+S key combination (text startup) or choosing the Setup button (graphics startup) during the initial power-on self-test (POST) routine.

To prevent unauthorized reconfiguration, the security system can disable access to BIOS Setup for individual users.

For more information, see Chapter 3, "Using the BIOS Setup Utility", and Chapter 6, "Using the Security System".

### **Using Apricot Help**

---

Along with the diskettes provided with your computer, or the software pre-installed on its hard disk, you will often find one or more Apricot Help files. These will explain any special features of the system, and tell you how to install the software needed to exploit those features.

For example, the files provided with the Apricot LS Pro include help on:

- Cirrus Logic CL-GD543x EVGA video drivers
- AMD PCnet-32 network drivers
- CrystalWare audio driver and utilities
- The Energy Star Programme

Apricot Help may be supplied in various forms, depending on the intended operating system; for the Microsoft MS-DOS/Windows operating system they are usually Windows help files or ASCII text files.

### **Viewing Windows help files**

Windows help files can be displayed only by the Microsoft Windows Help program (v3.1 or later). Windows help files may be identified by their *.HLP* file extensions, although this is not an infallible guide as some other help formats also use the *.HLP* extension. They are often accompanied by *.ICO* icon files of the same name.

If your computer has a hard disk on which Apricot has pre-installed Microsoft Windows, copies of some Windows help files may already be available as icons in the “Apricot” program group. To view the help file simply double-click on its icon, or select the icon and press **ENTER**. For more information about using Help, see your Windows documentation.

If the Windows help file you want to view is not already installed, or if for any other reason you need to view a Windows help file directly from a diskette:

1. Insert the diskette into a suitable drive.
2. Use Windows File Manager to view the contents of the diskette.

3. Choose the *.HLP* help file you want either by double-clicking on its filename or by selecting the filename with the cursor and then pressing ENTER.

The Windows Help program starts, displaying the first topic in the help file.

Alternatively, you can copy the Windows help file from the diskette to a hard disk or network drive, and create a program item for it using Program Manager. The help file can then be viewed at any time simply by double-clicking on its icon. To do this:

1. Insert the diskette into a suitable drive. Copy the *.HLP* help file, and its associated *.ICO* icon file if it has one, from the diskette to a hard disk or network drive.
2. Choose New from the File menu in Program Manager. Select the Program Item option in the New Program Object dialog box, then choose OK. The Program Item Properties dialog box appears.
3. In the Description text box, type a suitable title for the help file.
4. In the Command Line text box, type the path and filename of the help file (including its *.HLP* extension). Alternatively, choose the Browse button, find the help file, and choose OK.

Skip the next step if the help file doesn't have an associated icon file.

5. Choose Change Icon. The Change Icon dialog box appears. In the File Name text box, type the path and filename of the *.ICO* file. Choose OK.
6. In the Program Item Properties dialog box, choose OK.

### Viewing text files

ASCII text files, identified by their .TXT file extensions, can be read by most text editors and wordprocessing programs. Alternatively they can be displayed, one screenful at a time, using the DOS commands **type** and **more**; for example:

```
type helpfile.txt | more
```

### Version numbers

All the help files provided by Apricot have a version number so you can tell whether you're looking at the most up-to-date version. You can discover the version number of a Windows help file by viewing it with Help and choosing About Help from the Help menu.



# 3

## USING THE BIOS SETUP UTILITY

BIOS Setup is a utility programmed into the computer's read-only memory (ROM). Its main purpose is to allow you to view and alter the computer's hardware configuration. It is also used to configure the on-board security system. The current configuration is kept in a special area of memory, called CMOS memory, and maintained by a small battery. BIOS Setup can be accessed whenever the computer is turned on or rebooted.

This chapter describes how to access and use BIOS Setup, with the exception of the security system functions. For information on configuring the security system, see Chapter 6, "Using the Security System".

### ***Accessing BIOS Setup***

---

To prevent unauthorized reconfiguration, the security system can disable access to BIOS Setup for individual users.

To access the BIOS Setup utility:

1. Turn on or reboot the computer (for example, press CTRL+ALT+DEL in MS-DOS).
2. If the security system is enabled, logon to the computer using an account that includes the right to access the BIOS Setup utility.

BIOS sign-on and hardware configuration messages are displayed, either in text or graphics format according to how the startup mode is currently configured.

3. In text mode, press the ALT+S key combination when invited to do so. In graphics mode, use the mouse to click on the Setup button (or press ALT+S while the button is displayed).

The main BIOS Setup dialog box appears once POST is completed.



4. Use the BIOS Setup dialog to set basic configuration options. Choose the Advanced button to set advanced configuration options. Choose the Security button to configure the security system (see Chapter 6). The Security button is greyed-out if your user account does not include the right to access the LOC Technology Setup dialog.

BIOS Setup's dialog boxes look like Microsoft Windows dialog boxes, and work in a similar way. You can select and choose items with the mouse or the keyboard.

5. After you have made your changes, choose the Save button in the main BIOS Setup dialog to save the new configuration. Or choose the Cancel button to abandon all the changes you have made while in BIOS Setup.

If you have saved any changes, the computer will reboot automatically when you exit BIOS Setup.

## Using BIOS Setup dialogs

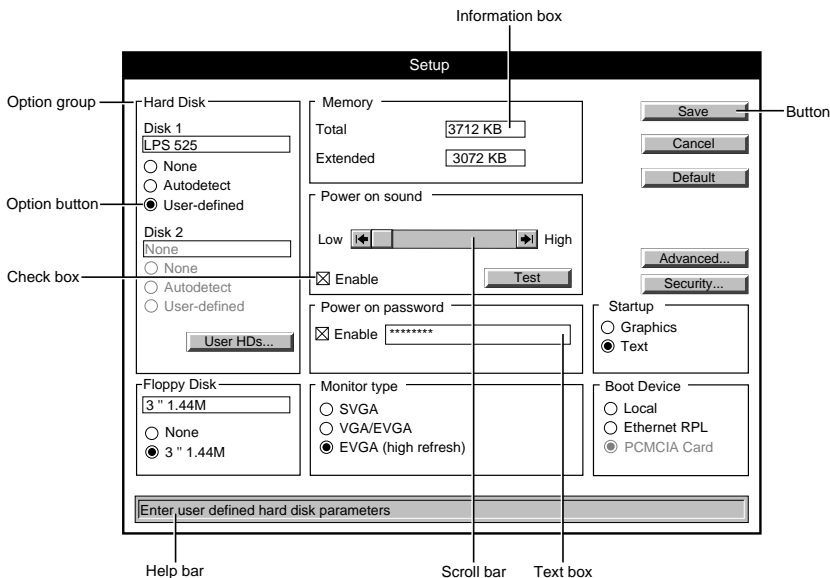

The following table lists the elements of BIOS Setup's user-interface.

<b>Element</b>	<b>Description</b>
Option groups	An option group collects a number of related or exclusive items under a common heading.
Buttons	You choose a button to initiate the action described by the text on the button. Some buttons are marked with an ellipsis (...); choosing this kind of button opens another dialog box.
Text boxes	You can type words or numbers into a text box. When you move to an empty text box, an insertion point (a flashing vertical bar) appears. The text you type starts at the insertion point.
Information boxes	These present information; their contents cannot be altered by you.
Option buttons	Option buttons represent a group of mutually exclusive options. You can select only one option at a time.
Check boxes	A check box presents non-exclusive options; you can select as many check-box options as needed.
Scroll bars	Scroll bars behave like slide controls. They are adjusted by pointing and clicking on the scroll arrows at each end of the bar.
Greyed-out options	When an option is dimmed or greyed-out it cannot currently be selected or chosen.
Help bar	The help bar displays information about the currently-selected option.

The simplest way to select or choose items is to point and click with a mouse. Note that the mouse is disabled while a text box is selected. If you prefer using the keyboard, you can use the following keystrokes:

Press	To
TAB or SHIFT+TAB	Move to the next or previous item in the dialog. To move directly to an item hold down the ALT key and press the character underlined in the item's name.
ARROW KEYS	Move between the items within an option group. Also to move the scroll box in a scroll bar.
SPACEBAR	Select or clear the currently-highlighted item (option button or check box).
ENTER	Choose the currently-highlighted button.

### Basic configuration options

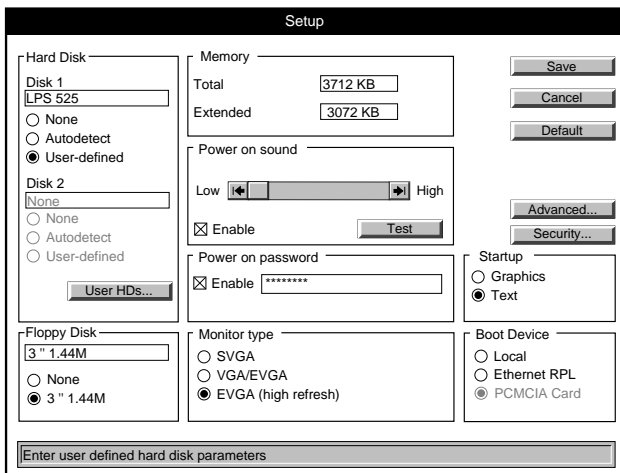

## Hard Disk

The Disk 1 information box shows the type and capacity of the computer's fixed hard disk drive, where known. Beneath this are three option buttons:

Option	Description
None	Select this if your computer does not have a fixed hard disk. This prevents the BIOS looking for a hard disk, and so speeds up the boot sequence.
Autodetect	Select this if your computer has a hard disk drive supplied by Apricot. In this case the BIOS will be able to detect the drive type automatically.
User-defined	Select this if your computer has a third-party hard disk drive not supplied by Apricot. You must then define the characteristics of the drive.

To define a third-party hard disk drive:

1. Choose the User HDs button.

The screenshot shows a dialog box titled "User defined hard disks". It contains two sections for "Disk 1" and "Disk 2". Each section has a table with four columns: "Cylinders", "Heads", "Sectors", and "Capacity (MB)". The values for Disk 1 are 097, 10, 17, and 0008. The values for Disk 2 are 097, 10, 17, and 0008. To the right of the Disk 1 section are buttons for "Save" and "Cancel". To the right of the Disk 2 section are buttons for "Detect 1" and "Detect 2".

2. In the User-defined Hard Disks dialog box, choose the Detect button to see if BIOS Setup can detect what type of drive is fitted. If it can, the characteristics of the drive appear in the dialog.

3. If BIOS Setup cannot detect the drive type, you must manually enter the drive's number of cylinders, heads and sectors, and its capacity, in the text boxes provided.
4. Choose the Save button.

The Disk 2 entries in the BIOS Setup and User-defined Hard Disk dialogs are provided for future development; they are greyed-out in the current version.

### **Floppy Disk**

The information box shows the type and capacity of the computer's diskette drive. Beneath it are two option buttons:

<b>Option</b>	<b>Description</b>
None	Select this if your computer does not have a diskette drive. This prevents the BIOS looking for a system diskette, and so speeds up the boot sequence.
3.5" 1.44M	Select this if your computer has a 1.44 Mbyte diskette drive.

### **Memory**

These information boxes show the total amount of system memory (motherboard memory plus any additional memory modules, minus the 384 Kbyte upper memory area) and the amount of extended memory (total memory minus the 640 Kbytes of conventional memory).

### **Power-on Sound**

When this option is enabled a tone will sound whenever the computer is turned on.

To set the power-on sound:

1. In the Power-on Sound group, select the Enable check box.
2. Choose the Test button to audition the power-on sound.
3. Use the scroll bar to adjust the volume of the power-on sound as required.

### **Power-on Password**

If this option is enabled a password must be entered every time the computer is turned on.

To set a power-on password:

1. In the Power-on Password group, select the Enable check box.
2. Select the text box, and type a password of up to seven characters using A-Z and 0-9. The password is not case-sensitive and cannot include space characters. To preserve security, the password is not displayed as you type but is shown as a string of asterisks.

The power-on password operates in addition to the security system features, if enabled.

### **Monitor Type**

These three options alter the timings of the video signals provided by the computer to suit a variety of different types of monitor.

It is important that you make the correct selection for your monitor. Check the documentation that accompanies the monitor to discover what resolutions and refresh rates (vertical scan frequencies) it supports.

Option	Resolution and refresh rates
SVGA	640x480 @ 60 Hz 800x600 @ 56 Hz 1024x768 @ 87 Hz Interlaced
VGA/EVGA	640x480 @ 60 Hz 800x600 @ 72 Hz 1024x768 @ 70 Hz
EVGA (high refresh)	640x480 @ 75 Hz 800x600 @ 75 Hz 1024x768 @ 75 Hz 1280x1024 @ 60 Hz

### Startup

The Startup options control how the display looks during POST, when BIOS sign-on and hardware configuration messages are displayed.

Option	Description
Graphics	During POST, a dialog box is displayed giving information about your computer, including the BIOS version, type of video controller and Ethernet node address. The dialog includes a Setup button for accessing BIOS Setup.
Text	The same information is displayed, but using only text. A message invites you to “Press Alt+S for SETUP”.

### Boot Device

These options allow you to select where you want the computer to look for an operating system when it boots.

Remote or network booting using Ethernet RPL won't work unless there's an RPL server somewhere in your network. Don't attempt to boot your computer in this way without first checking with the network administrator.

Option	Description
Local	The computer looks for a system diskette or a bootable hard disk partition (in that order).
Ethernet RPL	The computer attempts to load an operating system from a server elsewhere on the network, using the on-board Ethernet adapter and the Remote Program Load (RPL) code in the BIOS ROM.
PCMCIA Card	This option is provided for future development of BIOS Setup; it is greyed-out in the current version.

### Advanced configuration options

Advanced

<p>Parallel Port</p> <p><input type="radio"/> Standard</p> <p><input checked="" type="radio"/> EPP Compatible</p> <p><input type="radio"/> ECP Compatible</p> <hr/> <p>Disable</p> <p><input type="checkbox"/> Floppy Disk</p> <p><input type="checkbox"/> Floppy Write</p> <p><input type="checkbox"/> Floppy Boot</p> <p><input type="checkbox"/> Parallel Port</p> <p><input type="checkbox"/> Serial Port 1</p> <p><input type="checkbox"/> Serial Port 2</p> <p><input type="checkbox"/> Hard Disk Controller</p> <p><input type="checkbox"/> Ethernet</p> <p><input checked="" type="checkbox"/> BIOS Copy At 16MB</p> <p><input type="checkbox"/> i486 Cache</p> <p><input type="checkbox"/> External Cache</p> <p><input type="checkbox"/> BIOS Shadowing</p> <p><input type="checkbox"/> Large HD Translation</p>	<p>Energy Conservation</p> <p><input type="checkbox"/> Hard Disk Power Down</p> <p><input type="checkbox"/> CPU Power Management</p> <hr/> <p>CPU Power Management</p> <p><input checked="" type="checkbox"/> Keyboard</p> <p><input checked="" type="checkbox"/> Mouse</p> <p><input checked="" type="checkbox"/> Parallel port</p> <p><input type="checkbox"/> Serial port</p> <p><input type="checkbox"/> Hard Disk Controller</p> <p><input type="checkbox"/> Ethernet</p> <p><input type="checkbox"/> Floppy disk</p> <p><input type="checkbox"/> PCMCIA</p> <p style="text-align: right;">Inactivity timer (min.) <input style="width: 50px;" type="text" value="5"/></p>	<p><input type="button" value="Save"/></p> <p><input type="button" value="Default"/></p> <p><input type="button" value="Cancel"/></p>
--	---	---

Enhanced Parallel Port (EPP) Compatible



### Parallel Port

These three options allow you to set the mode of the parallel port.

Option	Description
Standard	Standard IBM AT-compatible bi-directional “Centronics” mode.
EPP Compatible	Compatible with the Enhanced Parallel Port standard.
ECP Compatible	Compatible with the Microsoft/Hewlett Packard Extended Capabilities Port standard.

### Disable

These check boxes allow you to disable various motherboard features or components. Obviously, you should not do this unless you are certain you will not need those features or components.

In particular, there is normally no reason to disable the internal or external memory cache, as doing so severely degrades the computer’s performance. Some old software which is speed sensitive may not work with caching enabled, but this is very unlikely nowadays.

However, you might want to disable some features for security reasons. For example, disabling the ability to boot from the diskette drive can help prevent the introduction of computer viruses into the system.

Occasionally, you may need to disable motherboard components to free system resources for use by PCMCIA cards (although in general the BIOS’s support for Plug and Play PCMCIA should make this unnecessary).

More information about the computer’s use of interrupts, DMA channels, memory and I/O ports is given in Appendix B, “Technical Information”.

Option	Meaning if selected
Floppy Disk	Disables the diskette drive controller.
Floppy Write	Disables the computer's ability to write to the diskette drive.
Floppy Boot	Disables the computer's ability to boot from a system diskette in the diskette drive.
Parallel Port	Disables the parallel port, freeing interrupt IRQ7 and I/O ports 3BCh-3BFh. However, IRQ7 can usually be "double-booked" without affecting the operation of the parallel port.
Serial Port 1	Disables serial port 1, freeing interrupt IRQ4 and I/O ports 3F8h-3FFh.
Serial Port 2	Disables serial port 2, freeing interrupt IRQ3 and I/O ports 2F8h-2FFh.
Hard Disk Controller	Disables the hard disk controller, freeing I/O ports 1F0h-1F8h and 3F6h-3F7h.
Ethernet	Disables the on-board network adapter, freeing interrupt IRQ5 and I/O ports 300h-317h. (However, interrupt IRQ5, even if free, cannot be used by the PCMCIA interface.)
BIOS Copy At 16MB	Disables the "copy" of the computer's BIOS ROM which normally appears in the computer's address space just below 16 Mbytes (between FE0000h and FFFFFFFh). This is not a real copy, just the same ROM addressed through a different (higher) set of memory addresses. This copy <b>must</b> be disabled if your computer actually has 16 Mbytes (or more) system memory, or the two will conflict.
i486 Cache	Disables the memory cache inside the system processor.
External Cache	Disables the external, or second-level memory cache, outside the system processor.
BIOS Shadowing	Disables the scheme whereby the contents of the computer's BIOS ROM are copied into system memory, where they can be accessed more quickly.
Large HD Translation	Disables the scheme (known as <i>Extended CHS</i> ) whereby the BIOS is able to access hard disk drives of greater than 504 Mbytes capacity. You might need to do this if your operating system does not support Extended CHS, in which case the drive will appear to have less than its full capacity.

### Energy Conservation

These options control the computer's power management features. If you disable them, the computer's system unit will no longer be Energy Star compliant (although the monitor may continue to comply).

Option	Meaning if selected
Hard Disk Power Down	Enables the feature that automatically spins down the hard disk after 20 minutes of inactivity.
CPU Power Management	Enables the feature that automatically slows down the system processor during periods of inactivity.

### CPU Power Management

These options control the feature that automatically cuts the system processor's external clock speed down to around 8 MHz during periods of inactivity (to reduce power consumption) and restores it to 25/33 MHz again when needed. This option group is greyed-out if CPU Power Management is disabled.

The check boxes allow you to select what events or activity will wake the processor.

In the Inactivity Timer text box, specify the period of inactivity after which the system processor will be slowed down.



## 4 NETWORKING

This chapter tells you how to physically connect your computer to an Ethernet network.

The physical network connection is only the first step in establishing a networking environment; you will also need the appropriate network software. Consult your network documentation or the person (or department) responsible for administering the network.

You must not attempt to connect your computer to the network without first informing the network administration or the other users of the network.

### ***What is Integrated Network Architecture?***

---

Integrated Network Architecture (INA) is Apricot's term for technology that makes it easier to connect your computer to an Ethernet network. ("Ethernet" is the more common name for the networking standard defined by the 802.3 Committee of the Institute of Electrical and Electronics Engineers or IEEE.)

At the heart of INA is the Advanced Micro Devices' PCnet-32 VESA local bus Ethernet adapter.

There are three network ports on the rear of the computer, one for each of three alternative types of Ethernet cabling: thin-Ethernet (formally designated as 10Base-2), thick-Ethernet (10Base-5) and twisted-pair Ethernet or TPE (10Base-T). You can only use one port at a time, and must set a jumper inside the computer accordingly.

Support for remote booting using the industry-standard Remote Program Load (RPL) protocol is provided directly in BIOS, so a separate remote boot ROM is not needed.

Apricot provides a comprehensive set of network drivers for the PCnet adapter. For more information, view the Apricot Help file that accompanies the drivers.

## ***Finding out about your network***

---

An Ethernet network may contain as few as two computers or many hundreds. Obviously, the size and complexity of your network will determine exactly how you should go about making the connection to it.

If yours is a large or well-established network, you may find that the network cabling has been laid in ducts under the floor, or in the walls, of your workplace, and that suitable network outlets have been provided nearby for you to plug into. There may also be a network administrator (or possibly a network administration department) whose job it to help new users connect to the network.

On the other hand, if your network is small, the procedure may be more informal. This is particularly likely to be the case if you are running a peer-to-peer network. The network cabling may be in plain view, and connection of your computer may simply involve attaching, with the cooperation of your fellow networkers, the correct cable to the correct Ethernet port.

So, before you connect your computer, you should find out the answers to a few questions about your network:

- 1. Is there a network administrator or network administration department?**

If there is, tell them that you want to add a new node and ask for connection instructions. All but the smallest networks require some form of network administration, and any instructions you get from them will always be more pertinent than the guidelines contained in this manual.

2. **What type of cabling does your network use: thin, thick or twisted pair?**

You will need to ensure that the adapter is correctly configured for your network.

3. **Is there a nearby network outlet you can plug into, or must you connect directly to the network cabling?**

Obviously a pre-installed network outlet makes your task much easier. If you must connect directly to the network cabling, you will have to keep in mind the various technical limitations of your particular type of Ethernet cabling.

### **Selecting thick- or thin-Ethernet**

---

If your network uses thick-Ethernet cabling, you may have to change a jumper setting inside the computer, as it is usually set to use thin-Ethernet. For more information, see the section on “Changing jumper settings” in Appendix A, “Inside the System Unit”.

### **Connecting Ethernet cables**

---

Remember to find out if your network has a network administrator or a network administration department, and if so seek their prior authorization and assistance. Their instructions will always be more pertinent than those provided here.

---

#### **Warning**

*Before connecting any network cables, turn off the computer and unplug all power cords. Make sure that network is not in use; existing network users should be logged off.*

---

### Thin Ethernet

A thin-Ethernet system uses flexible coaxial cable that is less expensive than a thick-Ethernet system (described in the next section) and is usually easier to set up.

Use the following illustration as a guide to connecting your computer to a thin-Ethernet system.

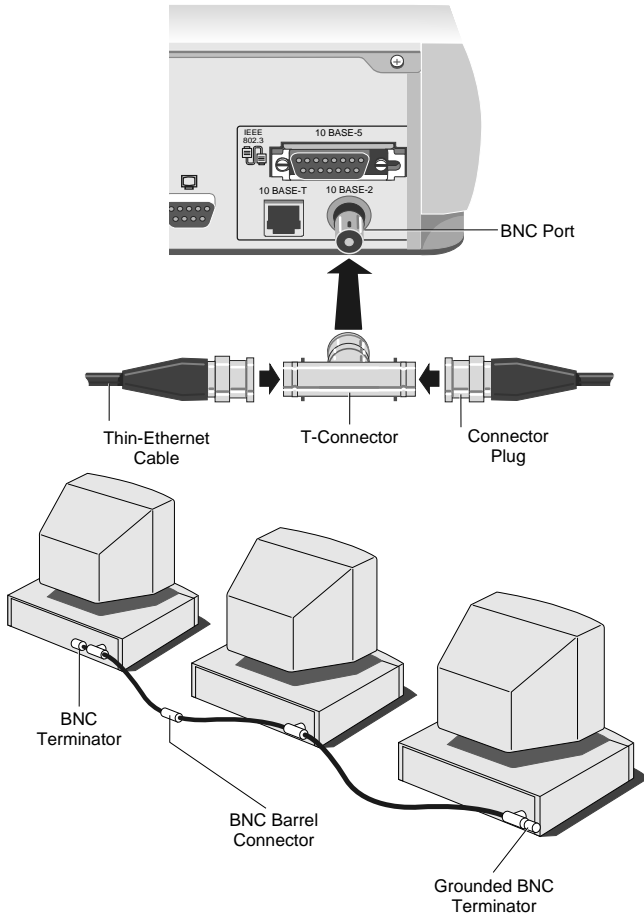



The following table describes the hardware components.

Item	Description
BNC port	The BNC port on the back of the computer connects it to a BNC T-connector.
BNC T-connector	The T-connector connects to the BNC port, and thin-Ethernet cables are connected to the crossbar of the T-connector. (For computers at the ends of the network, a terminator replaces one of the cables.)
Thin-Ethernet cable	<p>High-quality thin coaxial cable (RG-58 A/U or C/U), with a nominal impedance of 50 ohm, for networks that use the IEEE 802.3 10Base-2 standard (e.g. Belden 9907).</p> <p>A thin-Ethernet cable has BNC connectors at each end, for connection to BNC T-connectors or barrel connectors.</p>
Thin-Ethernet segment	<p>Thin-Ethernet cable can normally be used in segments up to 185 metres long, and can have a maximum of 30 nodes (computers or other networked devices) per segment. Neighbouring nodes must be separated by at least 50 cm of cable.</p> <p>A segment must always be a line; however many twists and turns it has it must never branch or form a loop.</p> <p>Up to five segments can be joined together by signal repeaters, bridges and routers.</p>
BNC terminator	When a computer is at the end of a segment, a terminator must be connected to the open end of the computer's T-connector. Terminators used with RG-58 cable must be 50 ohm.
Grounded terminator	It is recommended that the terminator at one end of the network is a grounded terminator. The grounded terminator has a grounding wire connected to it.
BNC barrel connector	A barrel connector can be used to join two pieces of Ethernet cable. Keeping the number of barrel connections on a network to a minimum increases network reliability. Do not use T-connectors in place of barrel connectors.

Apricot supplies Thin-cable Ethernet Network Starter and Thin-cable Ethernet Node Addition packs which can help you build simple Ethernet segments. Ask your Apricot supplier for details.

It is possible to remove the T-connector from the rear of your computer for a short time without disrupting the network. For example, you might remove it temporarily while you relocate your computer. However, the open end of the T-connector is a source of interference to the network signals, so do not leave it disconnected for too long. If you have to disconnect your computer from the network for a long time, you should replace the T-connector with a barrel connector.

### **Thick Ethernet**

A thick-Ethernet system uses rugged, heavily-insulated coaxial cable. With thick cable, you can connect more computers and the distance between them can be greater, but the cable is more expensive and more difficult to install than thin-Ethernet cable.

Use the following illustration as a guide to connecting your computer to a thick-Ethernet system.

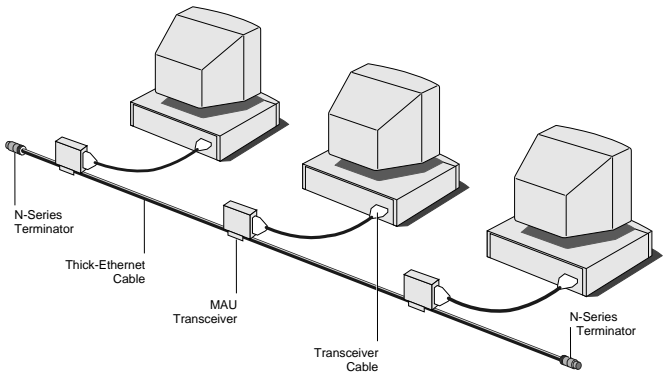
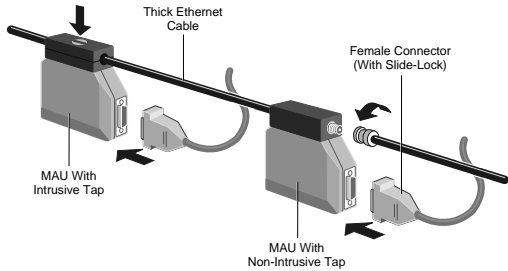
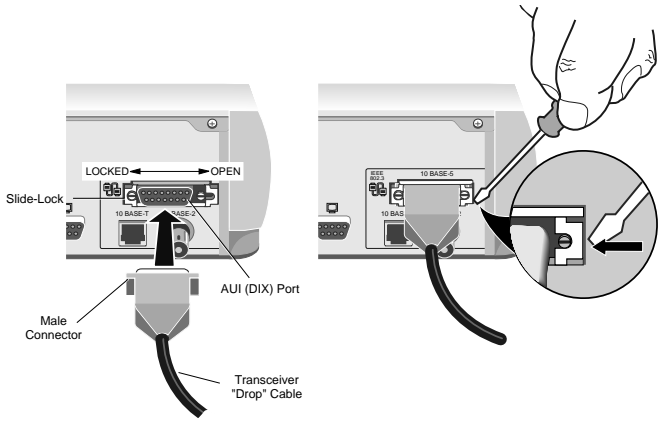

The following table describes the hardware components.

Item	Description
AUI (DIX) port	<p>The AUI or attachment unit interface port on the back of the computer connects it to a length of transceiver cable. The AUI port has a sliding latch that locks the cable connector onto the port.</p> <p>The AUI port is sometimes referred to as a DIX port (after Digital, Intel and Xerox, the original developers of Ethernet).</p>
Transceiver “drop” cable	<p>A transceiver or drop cable connects your computer to an MAU transceiver on a thick-Ethernet system. (The thick-Ethernet cable is too inflexible to be attached directly to the computer itself.)</p> <p>A male connector is located at one end of the transceiver cable; this attaches to the computer. A female connector (with slide-lock) is located at the other end; this attaches to the MAU transceiver (or to a network outlet).</p> <p>Maximum length for a transceiver cable is 50 metres.</p>
MAU transceiver	<p>An MAU (media attachment unit) transceiver connects the computer to the thick-Ethernet cable.</p> <p>MAUs are of two basic types: intrusive or vampire tap, and non-intrusive or N-series tap. An intrusive tap attaches by piercing the coaxial cable; the advantage of this is that the cable can be tapped at any convenient point. An non-intrusive tap can normally be installed only where the cable is interrupted by an N-series barrel connector.</p> <p>MAU transceivers are sometimes hidden behind network outlets. In this case the computer’s transceiver cable attaches to a nearby network outlet.</p>
Thick-Ethernet cable	<p>Thick coaxial cable with a nominal impedance of 50 ohm and marks at 2.5 metre intervals where it can be tapped, for networks that use the IEEE 802.3 10Base-5 standard (e.g. Belden 9880). Also known as “standard” cable.</p>

Item	Description
Thick-Ethernet segments	<p>Thick-Ethernet cable can be used in segments up to 500 metres long, and can have a maximum of 100 transceivers connected to it. Neighbouring transceivers must be separated by at least 2.5 metres of cable.</p> <p>Typically, a thick-Ethernet network is composed of a main segment or <i>spine</i>, with additional segments or <i>ribs</i> attached to the spine through signal repeaters, bridges or routers.</p>
N-series terminator	A terminator must be connected to the thick-Ethernet cable at each endpoint of the network.
Grounded terminator	It is recommended that the terminator at one end of the network is a grounded terminator. The grounded terminator has a grounding wire connected to it.
N-series barrel connector	A barrel connector can be used to join two pieces of thick-Ethernet cable.

## Twisted-pair Ethernet

The advantages of twisted-pair Ethernet (TPE) systems are that the cable is generally less expensive than systems such as thick-Ethernet, and the cable is relatively easy to install.

Use the following illustration as a guide to connecting your computer to a twisted-pair Ethernet system.

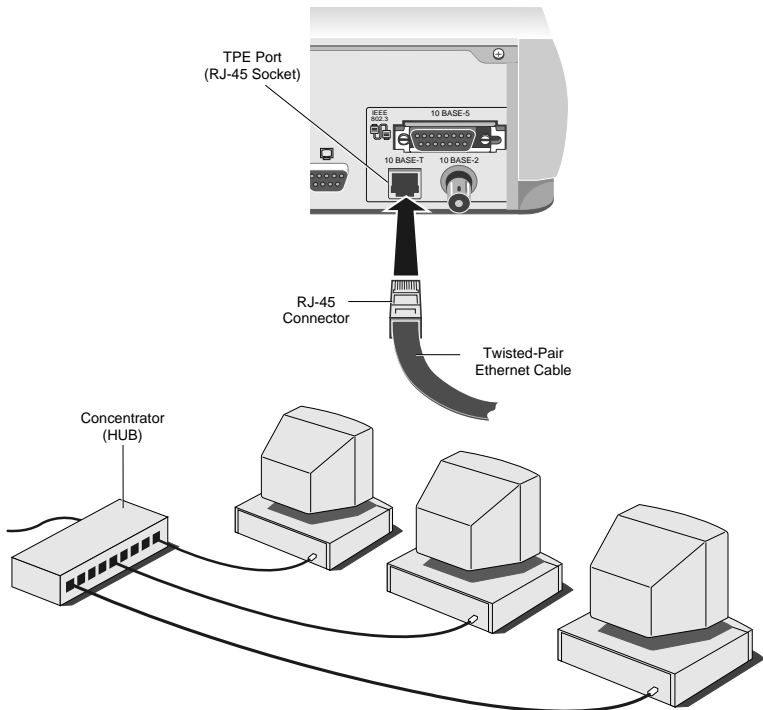

The following table describes the hardware components.

Item	Description
TPE port (RJ-45 socket)	The TPE port on the back of the computer connects it to the twisted-pair Ethernet cable.
Twisted-pair Ethernet cable	<p data-bbox="582 277 1014 501">Cable for a twisted-pair Ethernet system can be either unshielded twisted-pair (UTP) or shielded twisted-pair (STP). Both types of cable consist of two or more pairs of twisted copper wires; however, STP has a shielding layer of foil and copper braid around the inner cable that protects the wiring from electromagnetic interference or "noise". Shielded cable is more expensive, but recommended (e.g. Belden 9855).</p> <p data-bbox="582 517 1014 724">The cable should meet at least the minimum requirements of the IEEE 802.3i 10Base-T standard: it should be of 100 ohm impedance for a 5-10 MHz signal, and 0.5 mm or 24 AWG in diameter. 8-core untwisted and unshielded cable (e.g. FCC-68) is generally unsuitable and should only be used to connect the computer to an RJ-45 wall socket less than 2 metres away.</p> <p data-bbox="582 740 1014 868">Maximum cable length is 100 metres. If the path includes more than four RJ-45 plug/socket connections, reduce the maximum length by 15 metres for each additional connection. Do not add connections by splicing the cable.</p>
RJ-45 connector	An RJ-45 connector is located at each end of the twisted-pair cable. To connect the cable to the system unit, align the connector so the small plastic tab is in line with the slot in the TPE port (RJ-45 socket), and push in the connector until you hear a click. (The connector is similar to the plastic plug used to connect a telephone cord to a wall outlet.)
Concentrator or hub	<p data-bbox="582 1107 1014 1203">The computers in a TPE system are connected to each other by using a concentrator or <i>hub</i>. Cable from each computer is plugged into a socket at the hub.</p> <p data-bbox="582 1219 1014 1315">Hubs of various capacities are readily available, from desktop models with connectors for only a dozen computers to rack-mounted models which can interface over a hundred nodes.</p> <p data-bbox="582 1331 1014 1449">A small network can be built by connecting a group of computers using a single hub. For a larger network, twisted-pair cabling can be used to connect hubs. For greater distances still, hubs can be connected to an Ethernet segment.</p>





## 5 USING THE AUDIO SYSTEM

The Enhanced Business Audio system supports recording and playback of waveform (WAV) audio files, and playback of Musical Instrument Digital Interface (MIDI) audio files.

The system is based on the Crystal Semiconductor CS4231 chipset which incorporates 16-bit digital audio circuitry, a stereo analog mixer and an Ad Lib-compatible FM synthesizer.

The computer itself has an internal speaker, a master volume control, and stereo input/output sockets for microphone, headphones and line-level consumer audio.

### ***Connecting audio devices and controlling output volume***

---

There are two 3.5 mm stereo audio sockets on the left-hand side of the system unit; an input socket and an output socket.

#### ***Audio inputs***

The input socket, labelled with the  icon, allows the connection of audio sources to be used when monitoring or recording sound. You can connect a microphone (such as the one supplied), a personal stereo (tape or CD), or a line-in signal from a high-fidelity tape deck or CD player.

The mono microphone provided with the computer can be worn clipped to your clothing, or mounted on the keyboard. The microphone is switched on by sliding the cover back to expose the grille.

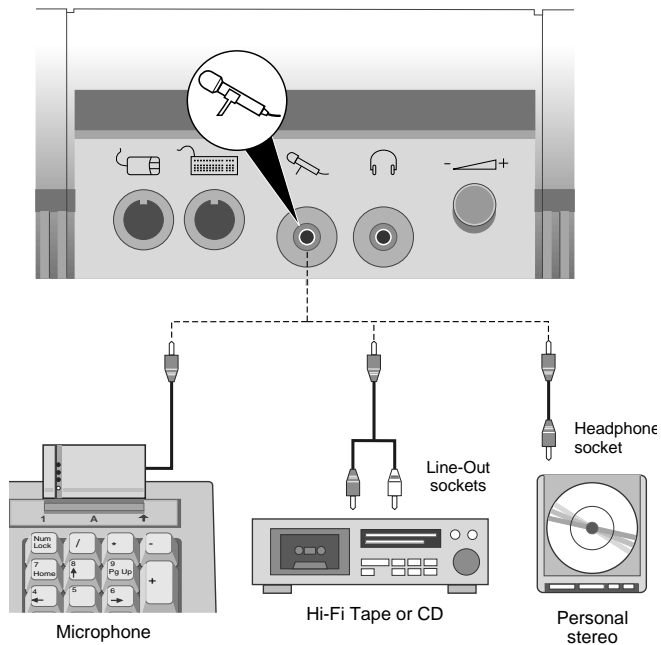

The audio system blends sounds from four sources:

- Digital audio (waveform playback)
- FM synthesizer (MIDI playback)
- PC audio (simple “beep” sounds)
- Audio input socket (microphone, personal stereo or line-in)

---

**Note**

*Copies of recorded music or other media should not be made without the publisher’s prior permission. Apricot accepts no responsibility in cases where this equipment has been used to make copies which infringe copyright.*

---

## Audio outputs

The output socket, labelled with the  icon, allows you to connect headphones or a pair of self-powered stereo speakers. Alternatively, it can provide a stereo line-out signal to a high-fidelity amplifier or tape deck.

The computer's internal speaker is disabled when an external device is connected to the output socket.

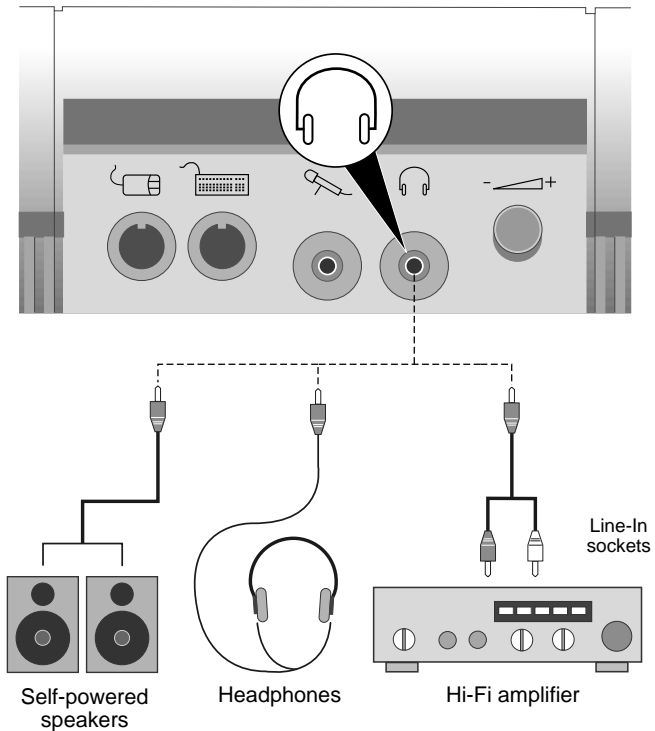

## Volume control

The master volume control allows you to change the absolute volume of sound output through the internal speaker or the audio output socket. This physical control moderates any software control. Turn the knob anti-clockwise to decrease the volume, clockwise to increase.

## ***Using the audio system under Microsoft Windows***

---

Support for the Enhanced Business Audio system under Microsoft Windows is provided by a CrystalWare audio device driver and some additional Windows utilities. See the accompanying Apricot Help file for more information.

## ***Using the audio system under MS-DOS***

---

The FM synthesizer component of the audio system is Ad Lib-compatible and can be used with most MS-DOS applications which support the Ad Lib standard.



## 6

# USING THE SECURITY SYSTEM

The Apricot LOC Technology v2.0 security system offers the ability to control who is allowed to use the computer, when, and to what extent. Properly used, the system helps to prevent misuse and deter theft.

The security system operates in addition to the power-on password that may be defined using the computer's BIOS Setup utility (see Chapter 3).

You need to read this chapter only if you are responsible for configuring the security system. If you are simply a user of the computer, turn to Appendix C, "Quick Guide To Security", for a brief overview.

### ***Features of the security system***

---

#### ***Security Setup in BIOS***

The security system is enabled and configured from the LOC Technology Setup dialog within the BIOS Setup utility. Access to the BIOS Setup utility, and the LOC Technology Setup dialog, can be controlled by the security system on a per-user basis.

#### ***KeyLOC card, user name and password***

The security system obliges users to logon every time the computer is turned on or rebooted. The logon sequence intervenes before the power-on self-test (POST).

For a fully-authenticated logon the user must present three items: a hand-held infrared device called a KeyLOC card, a user name, and a password. In situations where full authentication is deemed unnecessary, either the KeyLOC card or the user name and password may be omitted.

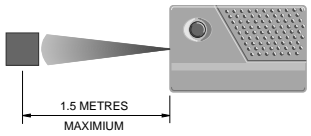
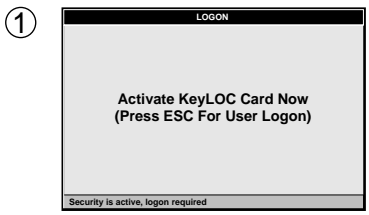

In addition, the user can be assigned logon periods that specify on what days of the week, and between what times, he is permitted to logon (for example, from 9:00 to 17:30, Monday to Friday).

A user is usually permitted to change his password when he logs on. He may also be forced to change his password every few days. Alternatively, a user may be barred from changing his password altogether.

The security system also supports a “Quick Logon” facility. This allows the creation of a “default” user account which has restricted user rights but which does not require any authentication at logon. This is helpful in situations where the computer has a majority of users with identical security

requirements. These users would rely on the Quick Logon account, whereas fully- or partially-authenticated logons would be reserved for special users such as the Master user.

### **Lockout period and alarm**

A lockout period can be imposed after three consecutive invalid logon attempts. This means that the computer is “locked” in the logon sequence. No further logons can be attempted until the lockout period expires. The user cannot circumvent the lockout period; the security system keeps track of elapsed time even when the computer is turned off.

Optionally, an alarm can be set to sound after four invalid logons (that is, during the second and subsequent lockouts).

### **User rights and account expiry**

The security system can deny an individual user access to the BIOS Setup utility and/or the LOC Technology Setup dialog. In addition, each user account can be given an expiry date (with the exception of the Master user account).

### **Master user**

One user account **must** be given “Master” status. The Master user can logon at any time and is always allowed to access the BIOS Setup utility and the LOC Technology Setup dialog. The Master user account can never expire, nor can it be given the Quick Logon facility (in other words, some authentication is always required).

Having a Master user account makes it impossible to set up a security configuration that no-one can alter.

### **Ownership string**

The ownership string identifies the owner of the computer, whether it is a person or an organization. The string is prominently displayed every time the computer is turned on or rebooted. The string cannot be altered or deleted except by those users who are permitted access to the LOC Technology Setup dialog.



The purpose of the ownership string is to deter theft by making the provenance of the computer clear.

### **Logon statistics**

The total number and last recorded date of valid logons and invalid logon attempts are displayed after each successful logon. These statistics can be reset from the LOC Technology Setup dialog.

This information can aid the detection of attempts to breach security.

### **System Identification Number**

The security configuration is stored in an area of protected memory and can only be changed from the LOC Technology Setup dialog. In exceptional circumstances it may be necessary to erase the configuration and start from scratch. This can be done by removing a jumper on the motherboard (see Appendix A for details).

When the computer is next turned on the security system asks for the computer's unique System Identification Number (SIN), at which point the BIOS Setup utility is started. The SIN therefore provides a "fail-safe" mechanism in case the jumper is removed maliciously in an attempt to by-pass security.

---

#### **Caution**

*The SIN is printed on a small label stuck onto the motherboard. To preserve security, this label **must be removed** and the SIN recorded in a safe, secure place.*

---

## **Configuring the security system**

---

The security system is enabled and configured from the LOC Technology Setup dialog within the BIOS Setup utility. Once the system is enabled, individual users may be barred from accessing the BIOS Setup utility and/or the LOC Technology Setup dialog.

To configure the security system:

1. Turn on or reboot the computer (for example, press CTRL+ALT+DEL in MS-DOS).
2. If the security system is already enabled, logon to the computer using an account that includes the right to access the LOC Technology Setup dialog.

BIOS sign-on and hardware configuration messages are displayed, either in text or graphics (Windows-like) format according to how the startup mode is currently configured.

3. In text mode, press the ALT+S key combination when invited to do so. In graphics mode, use the mouse to click on the Setup button (or press ALT+S while the button is displayed).

The main BIOS Setup dialog box appears once POST is completed.

4. In the BIOS Setup dialog, choose the Security button.
5. In the LOC Technology Setup dialog, set up the global options you want. See the section on “Setting up a security configuration” later in this chapter for details.
6. To define user accounts, choose the Set Users button.
7. In the User Setup dialog, set up the account details you want. See the section on “Defining user accounts” later in this chapter for details.

Choose the Delete User button to make this account vacant.

Choose the Next User button to cycle through the accounts to find a vacant account or the next account you want to edit.

When you have finished, choose the OK button.

8. In the LOC Technology Setup dialog, choose the Change Status button to set the Security Status to “Enabled” or “Disabled”, as required.

The security system has no effect until it is enabled.

9. Choose the Save button to save the new security configuration in memory.
10. In the BIOS Setup dialog, choose the Save button.

### Setting up a security configuration

In the LOC Technology Setup dialog box you can configure Lockout Control, Security Password Configuration, Logon Administration and the Ownership String.

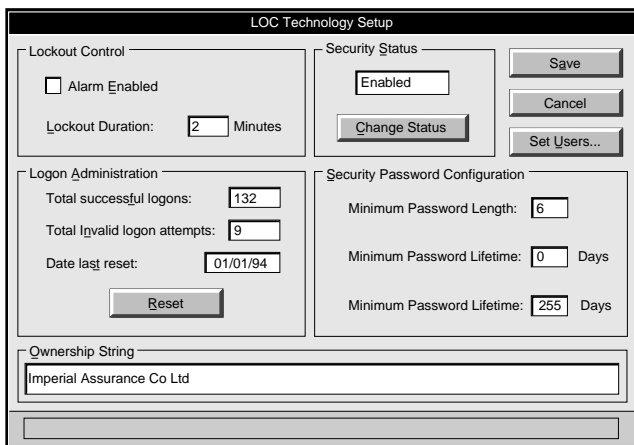

#### Lockout Control

A lockout period can be imposed after three invalid logon attempts, and an alarm can sound during the lockouts caused by the fourth (and subsequent) attempts.

When setting the lockout duration, bear in mind that most invalid logons will be caused by users forgetting or mistyping their user names or passwords. You will have to balance the

frustration caused to legitimate (if forgetful) users against the need to deter repeated attempts to breach security. It is always advisable to have lockouts enabled.

To set a lockout period and alarm:

1. Ensure that the Security Status is “Enabled” (choose the Change Status button if it is not).
2. Type the lockout duration in the Lockout Duration box (between 1 and 255 minutes, or up to 4.25 hours).
3. If an alarm is required, select the Alarm Enabled check box.

To disable both the lockout and the alarm without disabling the security system, set a lockout duration of zero minutes.

### **Security Password Configuration**

The Security Password Configuration settings apply restrictions on the use of passwords to increase the effectiveness of the security system.

The *minimum password length* is the minimum number of characters allowed in any user’s password.

The *minimum password lifetime* is the minimum number of days that must elapse before any user can change his password. Sometimes a user, annoyed at being forced to change his password (or worried about forgetting the new one) will be tempted to change back to the old one soon afterward. The minimum password lifetime feature will prevent this.

The *maximum password lifetime* is the number of days that a user’s password will remain valid; after this, the user will be forced to change his password at the next logon attempt. The maximum password lifetime applies only to those users who have the Expiry (Password) attribute set in their user accounts.

To set the security password configuration:

1. Ensure that the Security Status is “Enabled” (choose the Change Status button if it is not).
2. Type the minimum password length in the Minimum Password Length box (between 1 and 8 characters).

Set a minimum length of at least 6 characters; the more characters a password has, the more difficult it will be to guess.

3. Type the minimum password lifetime in the Minimum Password Lifetime box (between 0 and 255 days, or up to 9 months).

A minimum lifetime of 0 days allows a user to change his password at any time, unless the Lock Password attribute is set in his user account.

4. Type the maximum password lifetime in the Maximum Password Lifetime box (between 1 and 255 days).

Set a relatively short maximum; the longer a password remains current, the greater the chance of its being discovered.

### **Logon Administration**

Logon Administration shows the history of logon attempts at the computer:

- Total number of successful logons since the logon statistics were last reset.
- Total number of invalid logons since the logon statistics were last reset. This total includes attempted logons outside a user’s permitted logon periods.
- The date when the logon statistics were last reset.

To reset the logon statistics:

1. Ensure that the Security Status is “Enabled” (choose the Change Status button if it is not).

2. Choose the Reset button.

This not only resets the logon statistics shown in the LOC Technology Setup dialog, but also those displayed after each successful logon (see the section on “Understanding the logon sequence”, later in this chapter).

### Ownership String

The ownership string is displayed every time the computer is turned on or rebooted.

Don't set an ownership string without restricting access to the LOC Technology Setup dialog. Otherwise, anyone using the computer will be able to change or delete the ownership string.

To set the ownership string:

1. Ensure that the Security Status is “Enabled” (choose the Change Status button if it is not).
2. Type the ownership string into the Ownership String box. You can use up to 40 characters.

### Defining user accounts

You set up user accounts using the User Setup dialog box.

**User Setup**

**User Information**

User Account:   Master Status

Password:

**Expiry**

User Account:  /  /

Password:  /  /

KeyLOC card NOT SET

**Logon Selection**

Don't ask for Authentication at logon (Quick logon)

Ask for the following items at logon

KeyLOC Card

User name and Password

**User Rights**

BIOS Setup Disable

Security Setup Disable

Lock Password

Lock Keyboard

If you define any user accounts, you **must** include one (and only one) Master user account. You do not have to enable the security system before defining user accounts. The number of user accounts is limited by the capacity of the CMOS memory. This may vary for different models.

## User Information

Under User Information you provide details of the user name, password, KeyLOC card (if any) and logon periods.

Each account must have a unique user name, even if you don't plan to ask for it at logon (see "Logon Selection" below). You are also recommended to set a password. Users are allowed to share KeyLOC cards, but it is best if they have one each.

For ordinary users, you can set a date when the user account will expire. After this date, the user will be unable to logon, and attempts to do so will be counted as invalid logons.

You can also set a date when the user's password will expire, by applying the maximum password lifetime. After this date the user is allowed to logon one more time with his old password, but is then forced to change it, at which point the password expiry date is recalculated.

If you don't set a password expiry date, the password will never expire. However, the user can still change his password voluntarily, provided that the Lock Password attribute is not set (see "User Rights" below).

Again for ordinary users, you can set a permitted logon period for each day of the week.

To set the user information:

1. Type the user name in the User Name text box. You must use a different name for each user account.
2. Type the password in the Password text box and press ENTER. Then re-type the password to confirm it.

To preserve security, the password appears as a string of asterisks. Remember that there may be a minimum password length.

User names and passwords can each have up to 8 characters, selected from A-Z, a-z, 0-9 and space.

3. If this is the Master user account, select the Master Status check box.

When you select Master Status, some of the other controls in the User Setup dialog are disabled (they become dimmed or “greyed-out”). These changes are made to ensure that someone using the Master user account will always be able to logon and access the LOC Technology Setup dialog.

4. To set a date when the user account will expire, select the User Account check box in the Expiry section and then type the date next to it.

You cannot set an expiry date for the Master user account.

5. To ensure that the password will expire periodically, select the Password check box in the Expiry section. You do not need to type a date as it is automatically set to today’s date plus the maximum password lifetime. Thereafter, the expiry date is automatically re-calculated every time the user changes his password.

The Password check box is greyed-out if the Lock Password attribute is set; if a user cannot change his password it must not be allowed to expire.

6. If the user account requires a KeyLOC card, click on the Set KeyLOC Card button. Aim the KeyLOC card at the computer’s infrared sensor and press the button on the card. The card’s unique electronic signature is added to the security configuration.

The KeyLOC card will be rejected if it is already allocated to another user who has a “KeyLOC card only” logon.



7. To set logon periods for a non-Master user, choose the Logon Periods button. The Logon Periods dialog appears.

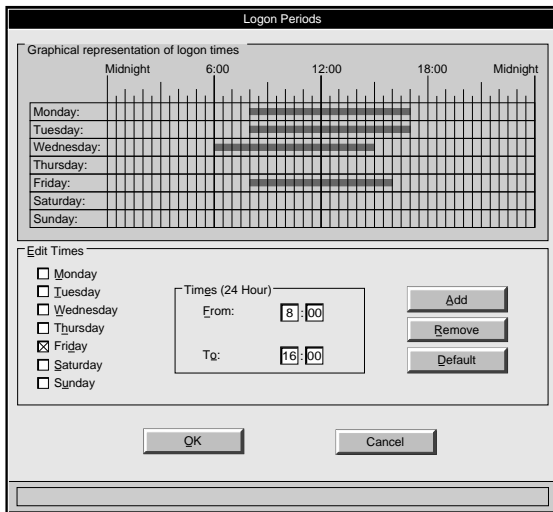

Use the check boxes in the Edit Times section to select the days of the week you want to edit.

To set a specific logon period for the selected day or days, type the start time (to the nearest 30 minutes) in the From box and the end time in the To box, then choose the Add button.

To remove the current logon period, choose the Remove button. This prevents the user logging-on at all on the selected day(s).

To apply the default logon period, choose the Default button. The default logon period is 24 hours, allowing unrestricted logons on the selected day(s).

8. When you are satisfied, choose the OK button.

## Logon Selection

In Logon Selection you specify what items of authentication are required at logon. Most user accounts will use one of three authentication schemes:

- KeyLOC card, user name and password.
- KeyLOC card only.
- User name and password only.

You cannot select a “KeyLOC card only” logon if the user is sharing his KeyLOC card with another user.

One user account (not the Master user account) can be given the Quick Logon facility, requiring no authentication. This account will then be used automatically by all users unless they specifically invoke the logon sequence and use a different account.

If Quick Logon is used it must be used carefully. In a multi-user configuration the Quick Logon account should have limited user rights, and should never be allowed to access the LOC Technology Setup dialog. See “User Rights” for more information.

## User Rights

Listed under User Rights are several check boxes. Use these to select what aspects of the computer the user is **not** allowed to use. At first, all rights are enabled.

User right	Meaning if selected
Setup Disable	The user cannot access the BIOS Setup utility.
Security Setup Disable	The user cannot access the LOC Technology Setup dialog within the BIOS Setup utility.
Lock Password	The user cannot change his password at logon. The Change Password check box in the User Logon dialog box is ignored if selected.
Lock Keyboard	After the computer boots, the keyboard is locked until the user enters his password.

The Setup Disable, Security Setup Disable and Lock Keyboard check boxes are greyed-out for the Master user account.

The Lock Password check box is greyed-out if the Expiry (Password) attribute is set. A user must always be permitted to change his password if it expires.

## **Understanding the logon sequence**

---

While the security system is disabled, the computer will boot as described in Chapter 2.

Once the security system is enabled, the logon sequence intervenes almost immediately after the computer is turned on or re-booted, unless the security configuration includes a Quick Logon account (see the section below on “Variations caused by Quick Logon”).

The diagram on page 6/15 summarises the logon sequence.

The Logon dialog box, requesting a KeyLOC card, will appear if the security configuration includes at least one account requiring KeyLOC card authentication.

The User Logon dialog appears if the user presses ESC at the Logon dialog or if his account requires full authentication. The User Logon dialog also appears if the KeyLOC card is not recognised; this masks the fact that the logon has already failed.

If the proffered authentication is not recognised, or if the user is outside his logon period for today, the logon attempt fails and the Logon or User Logon dialog re-appears. Repeated invalid logon attempts may cause lockouts and sound the lockout alarm, if these features are enabled (see diagram).

If the computer is turned off after one or more invalid logons, the security system remembers how many invalid logons there have been and will re-commence from the appropriate point in the logon sequence when the computer is next turned on.

### Logon Sequence

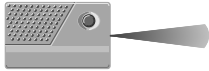
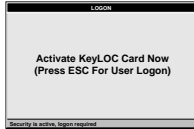

Valid Logon

### First Invalid Attempt



Status Bar says  
"Invalid Logon  
User not found!"

Repeat Logon  
Sequence

### Second Invalid Attempt



Status Bar says  
"Invalid Logon  
will cause lockout!"

Repeat Logon  
Sequence

### Third Invalid Attempt



LOCKOUT

Repeat Logon  
Sequence

### Fourth and Successive Attempts



ALARM



LOCKOUT

Repeat Logon  
Sequence

### What happens after logging-on?

After a successful logon, BIOS sign-on and hardware configuration messages are displayed, plus the ownership string (if defined), some logon statistics and, if the account includes the right to use BIOS Setup, an invitation to “Press ALT+S for Setup”:

Property of Imperial Assurance Co Ltd

No of valid Logons 11, Last valid logon 21-09-94  
No of invalid Logons 2, Last invalid logon 04-09-94

Press ALT+S for Setup

The number of valid and invalid logons, and the last invalid logon date, are statistics that are the same for all users. The *last valid logon* relates only to the currently logged-on user; it records the last date on which he (or someone using his user account) logged on. These statistics can be reset from the LOC Technology Setup dialog.

This information may be displayed as simple text (as shown above) or in Windows-like dialog boxes, depending on whether the Text or Graphics startup option is selected in BIOS Setup (see Chapter 3). In graphics mode, the effect of “Press ALT+S for Setup” is achieved by a Setup button in the startup dialog.

### Variations caused by Quick Logon

If the security configuration includes a user account with the Quick Logon facility, the logon sequence is not started *automatically* each time the computer is turned on or rebooted.

Instead, the usual BIOS sign-on, hardware configuration and security messages appear straight away. In this case the last valid logon date relates to the Quick Logon account, and “Press ALT+S for Setup” only appears if the Quick Logon account has the right to access BIOS Setup. In addition, however, there is an invitation to “Press ALT+L for Logon Sequence”:

Property of Imperial Assurance Co Ltd

No of valid logons 11, Last valid logon 21-09-94  
No of invalid logons 2, Last invalid logon 04-09-94

Press ALT+S for Setup  
Press ALT+L for Logon Sequence

If the user presses ALT+L when this final message appears, the logon sequence is started as described earlier. Otherwise, he is automatically logged-on using the Quick Logon account.

As before, this information may appear in text or graphical format. In graphics mode, the effect of "Press ALT+L for Logon Sequence" is achieved by a Logon button in the startup dialog.

## Changing a password at logon

---

A user is usually permitted to change his password when he logs on, by selecting the Change Password check box in the User Logon dialog before choosing OK. The Change Password dialog appears.

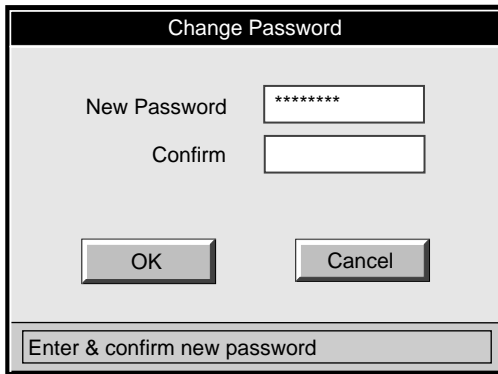

The image shows a graphical user interface dialog box titled "Change Password". It has a dark header bar with the title in white. The main area is light gray and contains two text input fields. The first field is labeled "New Password" and contains seven asterisks. The second field is labeled "Confirm" and is empty. Below the fields are two buttons: "OK" on the left and "Cancel" on the right. At the bottom of the dialog is a status bar with the text "Enter & confirm new password".

If the security configuration includes a minimum password lifetime, the user will not be allowed to change his password until this period has expired. A user is also not permitted to change his password voluntarily if his user account includes the Lock Password attribute. In these cases, the Change Password check box in the User Logon dialog is inactive.

On the other hand, a user can be forced to change his password if the security configuration specifies a maximum password lifetime. In this case, the Change Password dialog - retitled as the Password Expired dialog - appears once the user's password has expired, whether or not the user requests it.

## **Unattended mode for Microsoft Windows**

---

Temporarily unattended computers can pose a serious security problem; a secure logon procedure is worthless if a ten-minute coffee break can leave the whole system exposed. On the other hand, it is inconvenient to have to turn off the computer for only a short absence.

An optional enhancement to the security system offers an "unattended mode" for the Microsoft Windows operating system. When leaving the computer unattended for a time, a user can click the button on his KeyLOC card to obscure the screen and lock the keyboard and mouse; Windows continues working "behind the scenes". When the user returns, another click of the button cancels unattended mode.

Unattended mode can be invoked and cancelled only by the currently-logged-on user or by the Master user (provided that they have KeyLOC cards).

Unattended mode requires a hardware upgrade (this may be pre-installed), a Windows device driver, and a program called LOC Saver for Windows. LOC Saver allows the user to select a *.BMP* file with which to obscure the screen. The user can specify an inactivity timeout too, so that LOC Saver will act like a secure screen saver.

For more information, see the *LOC Saver User's Guide*.

## **Telling users about the security system**

---

You can photocopy Appendix C of this manual and give copies to each of the users of the computer as a *Quick Guide To Security*. You may want to back this up by explaining further the terms shown in **bold** (for example, **lockout period**). Note that users whose accounts do not include the right to use BIOS Setup need never know that such a utility even exists.





# 7

## USING PCMCIA CARDS

PCMCIA Cards or PC Cards are expansion devices for notebook and compact desktop computers. The primary benefits of PC Cards are their low power consumption, small size, ease of installation and ruggedness.

A wide variety of PC Cards are already available including LAN adapters, fax/modems, various memory cards, and ATA-standard hard disk drives. New cards are coming onto the market all the time.

### ***What is PCMCIA?***

---

The standards for PC Cards are defined by the Personal Computer Memory Card International Association. The abbreviation “PCMCIA” is variously used to refer to the expansion interface, the individual cards, or the whole technology.

The PCMCIA standards define three physical sizes of cards: Type I, Type II and Type III. All three card types are roughly the size of a standard credit card, and use the same 68-pin edge connector. They differ only in thickness: the thicknesses for Type I, Type II and Type III are 3.3 mm, 5.0 mm and 10.5 mm respectively.

The computer has a PCMCIA module with two slots or sockets that can accommodate the following card types:

---

<b>Slot</b>	<b>Type of card</b>
Slot 1 (upper)	Type I, Type II or Type III
Slot 2 (lower)	Type I or Type II

---

The PCMCIA standards also define the software needed to control the PCMCIA interface and configure PC Cards. This software is known as “Card & Socket Services” and supports the ability of PCMCIA-aware operating systems, applications and device drivers (also called *clients*) to share PC Cards, sockets and system resources.

PhoenixCARD Manager Plus (PCM+), is supplied with the computer. PCM+ includes an implementation of Card & Socket Services and a PCMCIA card configuration program for MS-DOS and Windows. See the *PCM+ User Guide* provided on the accompanying installation diskette for more information.

## ***Installing PCMCIA cards***

---

Most PCMCIA PC Cards come with client software (for example, a device driver) that needs to be installed before the card can be used. Many cards also come with a copy of Card & Socket Services, which of course you won't need.

Read the *User's Guide* or other documentation that accompanies the card to discover how to install the client software. This usually involves running an INSTALL utility.

Unfortunately, some INSTALL utilities insist on installing both the client software and Card & Socket Services. Check the card's documentation carefully; you may have to install the client software "manually", for example by copying a device driver onto the hard disk and editing the *CONFIG.SYS* file to include it.

## ***Inserting and removing PCMCIA cards***

---

You insert and remove a PCMCIA PC Card in much the same way as you insert and remove diskettes from the diskette drive.

Most cards can be safely inserted or removed while the computer is turned on, but some card manufacturers advise against this. Check the documentation that accompanies the card and, if necessary, turn off the computer before inserting the card.

Card & Socket Services usually sounds a "beep" when a card is inserted or removed (this can be disabled).

### **Inserting a card**

1. Check what type of card you have.

If it is a Type I or Type II card, you can use either Slot 1 or Slot 2. If it is a Type III card, you should use Slot 1.

2. Align the card with the chosen slot. The card should be inserted face uppermost.

Some cards have arrows or wording on them to indicate which way up they should be. Check the card's documentation if you are unsure.

3. Slide the card into the slot until the connector on the card engages with the socket.

This is designed to be a tight fit so a slight pressure may be required to engage the card. When the slot's eject button pops out, the card is seated correctly.

---

### **Caution**

Do **not** use excessive force. If the card does not seem to fit it is probably upside down.

---

### **Removing a card**

To remove a card:

1. Press the eject button next to the slot.

The eject button for Slot 1 is on the left of the slot; the button for Slot 2 is on the right. The card is disengaged from the socket and partially ejected.

2. Remove the card completely.

## Configuring PCMCIA cards

---

The following table describes the system resources commonly required by a PCMCIA PC Card.

Resource	Description
Memory windows	A memory window is a specified range of addresses within system memory, through which the PC Card's memory can be addressed. A card typically requires no more than one or two memory windows for use by its client software. Memory windows are typically located in the computer's <i>upper memory area</i> between addresses C8000h and DFFFFh.
I/O windows	An input/output (I/O) window specifies a range of I/O ports used to control the operation of the card. A card may have at most two I/O windows. Each I/O port is an address low down in the processor's address space, usually between 100h and 3FFh.
Interrupt	The <i>interrupt request level</i> or <i>IRQ</i> (the two terms are used interchangeably) is the line over which a PCMCIA card sends a signal to get the attention of, or interrupt, the processor. Three interrupts, IRQ9, IRQ10 and IRQ15, are already assigned for PCMCIA; IRQ3, IRQ4, IRQ7 and IRQ14 can also be used if required (although IRQ14 can only be used on systems without a hard disk).

In addition, Card & Socket Services itself requires an interrupt (used to detect card insertion and removal) and four kilobytes of upper memory (used to access the cards' configuration information). The preferred solution is to use IRQ10 and C8000h-C9000h.

In general, card resource allocation is handled automatically by Card & Socket Services. When a card is inserted, Card Services interrogates the card to discover what resources it requires, and allocates them if it is able. If necessary, unwanted motherboard components can be disabled by BIOS Setup to free resources (see Chapter 3).

A modem card should be configured to use the I/O ports and IRQ normally assigned to a serial port. Unless your operating system supports “Plug and Play” PCMCIA, you may need to disable one of the computer’s serial ports to free the required resources. See Appendix B, “Technical Information”, for more about the computer’s use of these resources.

---

**Note**

*With the advent of operating systems that support Plug and Play (PnP), there should be fewer conflicts between resources requested by PCMCIA cards and those used by motherboard components.*

---

If you are using a memory manager you must make sure that its **device** statement in *CONFIG.SYS* excludes those parts of the upper memory area that will be used by Card & Socket Services for memory windows. If you are using the Microsoft EMM386 Memory Manager, the PCM+ Setup Utility will do this automatically, but you should first remove all */i=* and */x=* arguments from the **device=emm386** command in *CONFIG.SYS*.

---

**Note**

*Memory addresses are always written in base 16 or hexadecimal notation. Unlike the ten digits of the decimal system (0-9), hexadecimal uses sixteen digits (0-9 and A-F, where A=10, B=11, C=12 and so on up to F=15). Hexadecimal numbers are denoted either by the suffix “h” or by the prefix “0x”. The final digit of a five-digit memory address is often omitted, so C8000h may be written as C800h.*

---



## 8

# MAINTAINING AND TRANSPORTING

This chapter provides information on how to care for your computer. You'll find that it requires little physical maintenance other than occasional cleaning. But you must take care when transporting it to avoid damage to its delicate components, particularly the hard disk.

---

### **Warning**

*Turn off the system unit and unplug all power cords before cleaning or moving the computer.*

---

## **Cleaning the computer**

---

### **The system unit**

Do not use sprays, solvents or abrasives that might damage the computer's finish. Do not use cleaning fluids or sprays near air vents or ports.

- Occasionally wipe the system unit with a soft, slightly damp, lint-free cloth.
- Occasionally clean the diskette drive using a proprietary head cleaner.

### **The monitor**

Occasionally wipe the monitor with a soft, slightly damp, lint-free cloth. It is best to use anti-static glass cleaner on the monitor screen, but do not spray glass cleaner directly onto the screen; it could run down inside the case and damage the circuitry.

### **The keyboard**

When necessary, clean the keycaps with a slightly damp cloth and a minimum amount of a non-abrasive cleaning agent.



Take care not to spill any liquid onto the keyboard. Follow these steps if you spill something on the keyboard and it stops working:

1. If the liquid is viscous, unplug the keyboard and call your supplier or an authorized maintainer.
2. If the liquid is thin and clear, try unplugging the keyboard, turning it upside down to let the liquid drain out, and drying it for at least 24 hours at room temperature. If the keyboard still won't work, call your supplier or an authorized maintainer.

If a solid object drops between the keys, turn the keyboard upside down and shake it; do not probe between the keys as this may cause damage.

### **The mouse**

Dust and dirt may accumulate in the ball tracking mechanism of the mouse. To clean the mouse:

1. Unplug the mouse, turn it upside down and locate the plastic cover that holds the ball in place. Depending on the model, the plastic cover can be removed either by rotating it counter-clockwise or sliding it forward slightly.
2. Remove the cover and set it aside.
3. Cupping one hand over the underside, turn the mouse back the right way up. The ball will drop into your hand.
4. Blow gently into the mouse to remove any dust that has collected there.
5. Inside the mouse there are three plastic rollers. Using a cotton swab moistened with a solvent cleaner, gently wipe off any oil or dust that has collected on the rollers, rotating them to reach all surfaces.
6. Use clear water, or water with a mild detergent, to clean the ball. Then dry it with a clean, lint-free cloth.
7. Put the ball back in its socket and replace the plastic cover. It should click into place.

## Recharging the configuration battery

---

The computer keeps a record of its current hardware configuration in a CMOS memory chip which is sustained by a small battery. The on-board security system, if enabled, also uses CMOS memory to store its security configuration.

Normally, this battery is kept charged by the AC power supply. If the computer is disconnected from the AC power supply for more than three months, the battery will become exhausted and the configuration data will be lost. When the computer is next turned on, several error messages will appear including:

RTC Power Failure

Please Reconfigure and Retry

Before doing anything, make sure you know the computer's unique System Identification Number (SIN). The SIN is normally printed on a label stuck onto the motherboard, but this label may have been removed as a security precaution. If the SIN label is missing, ask the person responsible for administering the security system for help.

1. You may be asked to enter the SIN. Type the SIN and press the ENTER key.  
The BIOS Setup utility starts automatically.
2. Use the BIOS Setup utility to reconfigure the hardware as described in Chapter 3.
3. If the security system was enabled, it too will have to be reconfigured and re-enabled as described in Chapter 6.
4. Leave the computer connected to the power supply for 24 hours to recharge the battery.

If the battery fails completely, and will not recharge, ask your supplier or an authorized maintainer for assistance.

## **Transporting the computer**

---

Use common sense when handling the computer; hard disks in particular can be damaged if the computer is dropped or handled roughly. As a precaution, back up (copy) the contents of your hard disks to a network drive, PCMCIA non-volatile memory card or diskettes before moving the computer.

Don't try to move the computer while it is plugged into the AC power supply or with any other cables, including network cables, still attached.

If you need to transport the computer any great distance, use the original packing materials.

If you intend to use the computer in another country, see the next section for some important advice.

## **Using the computer in another country**

---

Your computer arrives ready to work with the commercial AC power supply available in the country in which it is first sold.

If you plan to use the computer in another country, you should first check the following facts about your destination:

1. The voltage and frequency of the commercial AC power supply.
2. The type of plug required for the AC power outlets.

### **AC power supply**

Check the power rating labels on the rear of the computer's system unit and its monitor to ensure that they are compatible with the AC power supply.

---

### **Warning**

*It is imperative that the computer is set to the correct voltage range before use. If not, the machine may be irreparably damaged.*

---

The computer can function within two alternative AC power supply ranges, according to the position of the voltage selection switch on the rear of the system unit:

---

Switch setting	AC power supply (voltage and frequency)
115	100 - 120 volt AC, 50 - 60 Hz
230	220 - 240 volt AC, 50 - 60 Hz

---

The voltage setting of the monitor must always be the same as the voltage setting of the system unit. See the *User's Guide* that accompanies the monitor or consult your supplier to find out how to change the voltage setting.

Make sure that the system unit and the monitor are returned to their original voltage settings when you return home.

### **AC power cord**

The AC power cord and plug supplied with your computer comply with the safety standards applicable in the country in which it is first sold. If you plan to use the computer in another country, you must get a power cord that complies with the safety standards of the destination country. For further details, see the "Safety and Regulatory Notices" section at the start of this handbook.



## 9

## UPGRADING

This chapter provides step-by-step instructions on ways in which your computer can be upgraded in performance and capabilities.

Read the relevant instructions before deciding on a purchase, to see if you feel confident about performing the installation yourself. Remember that, to avoid damaging sensitive electronic components, all work that involves removing the computer's top cover must be done in an area completely free of static electricity. If you require assistance, please ask your supplier to install the upgrade for you.

Use the following illustration to identify the main components inside the system unit that are affected by the installation instructions provided in this chapter.

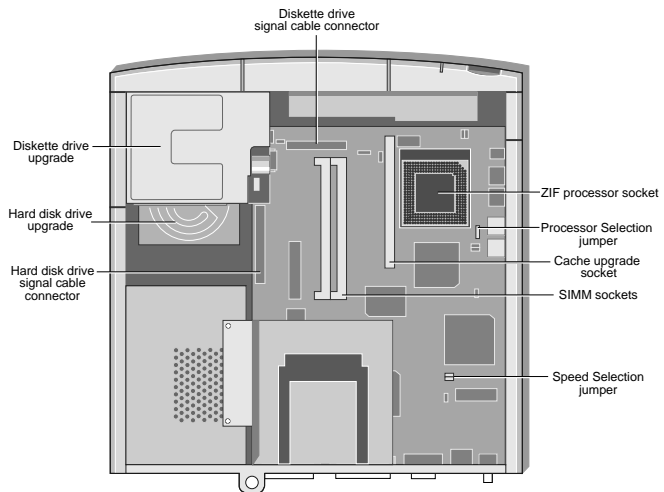

## Adding more memory

The computer has 4 megabytes (Mbytes or Mb) of random-access memory (RAM) fitted directly onto the motherboard. You can add more memory up to a maximum of 64 Mbytes by the use of one or two standard SIMMs (single in-line memory modules).

There are two SIMM sockets on the motherboard, labelled MM1 and MM2. Each socket can be left empty or fitted with a SIMM. SIMMs with capacities of 4, 8, 16 and 32 Mb are supported. When a 32 Mb SIMM is fitted in the MM2 socket, the 4 Mb motherboard memory is automatically disabled.

The following table shows the recommended configurations.

Total memory	Consisting of SIMMs and motherboard memory...		
	MM1	MM2	Motherboard
4 Mb	-	-	4 Mb
8 Mb	4 Mb	-	4 Mb
12 Mb	4 Mb	4 Mb	4 Mb
12 Mb	8 Mb	-	4 Mb
16 Mb	4 Mb	8 Mb	4 Mb
20 Mb	8 Mb	8 Mb	4 Mb
20 Mb	16 Mb	-	4 Mb
24 Mb	4 Mb	16 Mb	4 Mb
28 Mb	8 Mb	16 Mb	4 Mb
36 Mb	16 Mb	16 Mb	4 Mb
36 Mb	32 Mb	-	4 Mb
40 Mb	32 Mb	4 Mb	4 Mb
44 Mb	32 Mb	8 Mb	4 Mb
52 Mb	32 Mb	16 Mb	4 Mb
64 Mb	32 Mb	32 Mb	disabled

In most cases, it does not matter which SIMM goes in which socket, but some configurations are less efficient than others. If the BIOS detects an inefficient configuration it will prompt you to swap the SIMMs over when you next turn on the computer.

You cannot easily install a SIMM in the MM2 socket while the MMI socket is occupied. So either install the MM2 SIMM first, or temporarily remove the MMI SIMM if it is still required in the new configuration.

### ***Installing and removing SIMMs***

To locate the SIMM sockets:

1. Turn off the computer and unplug all power cords.
2. Take suitable anti-static precautions and remove the system unit cover.

If you are unfamiliar with anti-static precautions or the procedure for removing the system unit cover, see Appendix A, “Inside the System Unit”.

3. Use the illustration at the start of this chapter to locate the SIMM sockets.
4. Compare the current configuration of SIMMs with the recommended configuration for the memory upgrade you intend to install.

If necessary, remove one or both existing SIMMs, before going on to install the new SIMM(s).

To remove a SIMM:

1. Disengage the metal holding clips on each side of the socket using your forefingers. Place your thumbs on the top edge of the SIMM and tilt the SIMM to about 15° to the vertical.

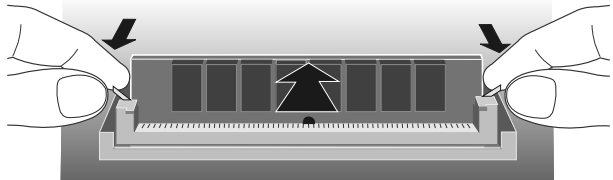

2. Lift the SIMM out of its socket. Hold the SIMM by its edges and avoid touching the metal contacts.



To install a SIMM:

1. Take the SIMM out of its anti-static packaging. Hold it by its edges and avoid touching the metal contacts.

Notice that the SIMM is not symmetrical; there is a small notch in one edge.

2. Place the SIMM in the socket at a 15° angle to the vertical, with the notched edge towards the rear of the system unit.
3. Pushing gently on its top corners, lean the SIMM upright in the socket until the pegs of the socket engage the holes on the SIMM and the metal clips hold the SIMM in position.

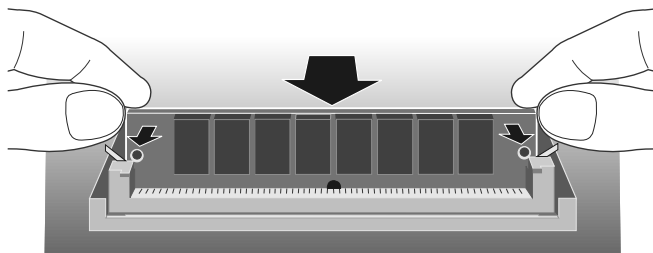

Do not use excessive force. If the SIMM will not fit easily, remove it and start again.

Repeat these steps if you want to install a second SIMM, then replace the system unit cover.

### **Reconfiguring the system**

The first time you turn on the computer after adding or removing SIMMs a POST error message appears, indicating that the amount of memory does not match the value stored in CMOS.

The BIOS Setup utility will be invoked automatically to allow you to confirm the new memory configuration. See Chapter 3, “Using the BIOS Setup utility”, for more information.

## Upgrading the processor

---

Your computer is supplied with an Intel486 or IntelDX4 processor.

The ZIF (zero insertion force) processor socket on the motherboard is designed to accept a variety of Intel processors. You can upgrade your processor by replacing it with one of higher performance.

Before purchasing a new processor you must check that its *operating voltage* is compatible with your system. Intel486 systems accept processors operating at 5 volts, IntelDX4 systems operate at 3.3 volts.

You must also find out the *external clock speed* of the new processor. This must be either 25 or 33 megahertz (MHz). Check carefully: the external clock speed is often only a fraction of the internal clock speed, which is usually the one advertised.

The following table shows the possible upgrade paths for Intel486 (5 volt) and IntelDX4 (3.3 volt) systems:

Intel486 systems	IntelDX4 systems
Pentium OverDrive-ready	Pentium OverDrive-ready
Intel486 DX2-66	IntelDX4-100
Intel486 DX2-50	
Intel486 DX2 OverDrive	
Intel486 DX-33	
Intel486 SX-33	

### Removing and fitting a processor

To remove the existing processor:

1. Turn off the computer and unplug all power cords.
2. Take suitable anti-static precautions and remove the system unit cover.

If you are unfamiliar with anti-static precautions or the procedure for removing the system unit cover, see Appendix A, “Inside the System Unit”.

3. If the computer was turned on prior to commencing this procedure, **wait for at least 15 minutes** for the processor to cool down before proceeding.

---

#### **Warning**

*The processor can get **very** hot. You may burn your fingers if you attempt to remove the processor before it has cooled down. Also, the processor’s pins expand slightly when hot and this can prevent it being removed from the socket.*

---

4. Use the illustration at the start of this chapter to locate the ZIF processor socket.  
A lever attached to the socket secures the processor in the socket.
5. Lift the lever from the locked position until it is upright (at right-angles to the motherboard). The first and last 15° of movement may require significant effort. Apply just enough pressure to overcome the resistance offered by the lever.

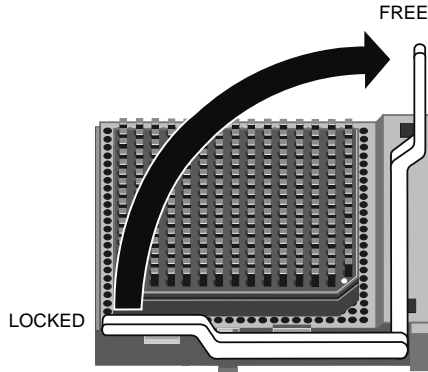

6. Lift the processor out of the socket and place it on an anti-static surface outside the system unit. Hold the processor by its edges and avoid touching the metal pins.

---

#### **Caution**

*If the processor does not lift easily out of the socket, do **not** attempt to force it. Wait for the processor to cool down.*

---

To fit the upgrade processor:

1. Ensure that the securing lever on the ZIF socket is still in the upright position.
2. Take the upgrade processor out of its anti-static packaging. Hold the processor by its edges and avoid touching the metal pins.

The upgrade processor and the ZIF socket are keyed to ensure that the processor is installed in the correct orientation. One corner of the socket has a key hole. The corresponding corner of the processor is slightly bevelled and has a positioning guide in the form of a coloured dot.

3. Place the processor in the socket, making sure that it is correctly aligned and that you do not bend or otherwise damage the pins.

If the upgrade processor is not big enough to occupy all four rows of holes in the socket it should be positioned centrally as shown below.

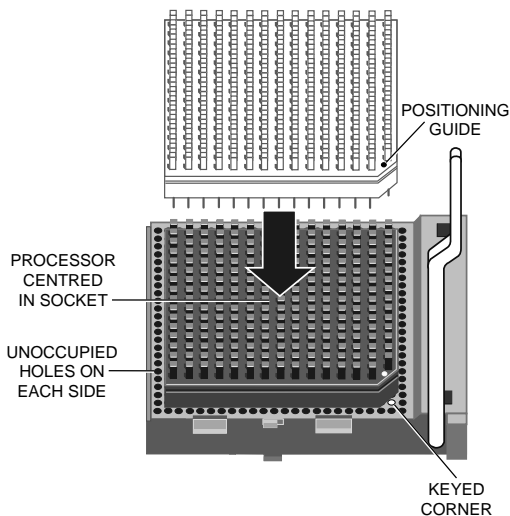

---

### Caution

*If the processor is misaligned it will not go into the socket, and any attempt to force it will damage the processor, or the socket, or both.*

---

4. Move the securing lever to the locked position. Apply just enough pressure to overcome the resistance offered by the lever.
5. You may need to adjust some jumper settings on the motherboard:

If you have replaced an Intel486 SX processor with any other type, you must move the Processor Selection jumper from “SX” to “Other”.

If the new processor has a different external clock speed than the one it replaced, you must move the Speed Selection jumper.

See Appendix A, “Inside the System Unit”, for more information about locating and adjusting motherboard jumper settings.

6. Replace the system unit cover.

## ***Adding an external cache***

---

An *external cache* is an area of dedicated memory with significantly faster access times than the computer’s main random-access memory (RAM). A cache controller ensures that the cache contains copies of the most recently accessed areas of RAM, so that the processor is able to read it much more quickly.

An external cache is sometimes called a second-level cache, to distinguish it from the first-level cache contained within the processor itself.

The addition of a 256 Kbyte external cache can significantly improve the performance of your computer.

To fit the external cache:

1. Turn off the computer and unplug all power cords.
2. Take suitable anti-static precautions and remove the system unit cover.

If you are unfamiliar with anti-static precautions or the procedure for removing the system unit cover, see Appendix A, “Inside the System Unit”.

3. Use the illustration at the start of this chapter to locate the cache socket.
4. Take the cache upgrade out of its anti-static packaging. Hold it by its edges and avoid touching the metal contacts.

Notice that the cache upgrade is not symmetrical; there is a small notch in one edge.

5. Insert the cache upgrade into its socket with the notched edge towards the rear of the system unit. Keep the upgrade level as you insert it.
6. Replace the system unit cover.

## Adding a diskette drive

---

You can add a diskette drive to a currently diskless system. The upgrade kit includes the drive itself, the mounting bracket, fixing screws, and the drive signal cable.

To fit the diskette drive:

1. Turn off the computer and unplug all power cords.
2. Take suitable anti-static precautions and remove the system unit cover.

If you are unfamiliar with anti-static precautions or the procedure for removing the system unit cover, see Appendix A, "Inside the System Unit".

3. Remove the metal blanking plate and plastic cover from the side of the system unit to uncover the diskette drive aperture.

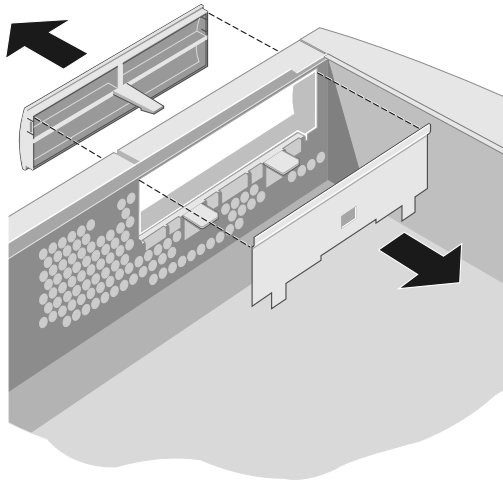

- Secure the diskette drive to the mounting bracket using the four fixing screws. Fit pair “A” first, then “B”.

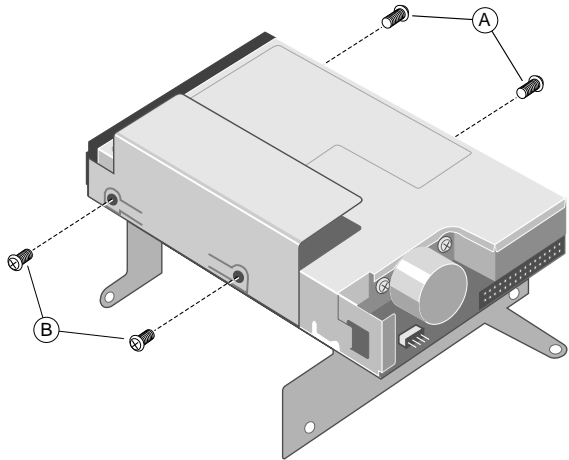

- Coax the mounting bracket and the attached diskette drive into position, feeding the front of the drive into the aperture until the metal flanges on the lip of the aperture engage with the front of the mounting bracket. When the bracket is correctly positioned, it also engages with two slots in the base of the system unit.

Secure the mounting bracket to the base of the system unit using the single fixing screw provided.

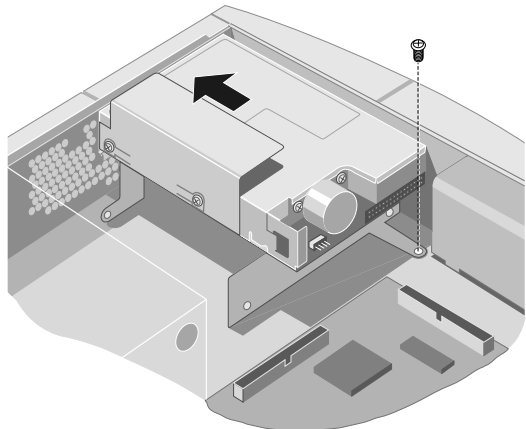



6. There should be three spare (unused) power cables coming from the power supply unit. The cable with the medium-sized connector is the diskette drive power cable; connect it to the rear of the diskette drive. The connector will only fit in one orientation.
7. Attach the signal cable between the drive and the motherboard connector.

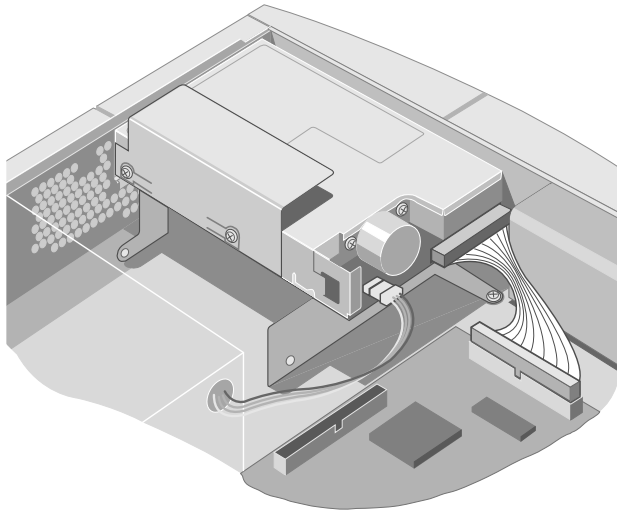

8. Replace the system unit cover.

## Adding a hard disk drive

---

You can add a hard disk drive to a currently diskette-only system. The upgrade kit includes the drive itself, fixing screws and the drive signal cable.

To fit the hard disk drive:

1. Turn off the computer and unplug all power cords.
2. Take suitable anti-static precautions and remove the system unit cover.

If you are unfamiliar with anti-static precautions or the procedure for removing the system unit cover, see Appendix A, “Inside the System Unit”.

3. Unplug the diskette drive signal and power cables from the rear of the drive. (You may find it helpful to disconnect the signal cable from the motherboard too.)
4. Remove the screw that secures the mounting bracket to the base of the system unit.

Coax the mounting bracket and attached diskette drive out of the system unit.

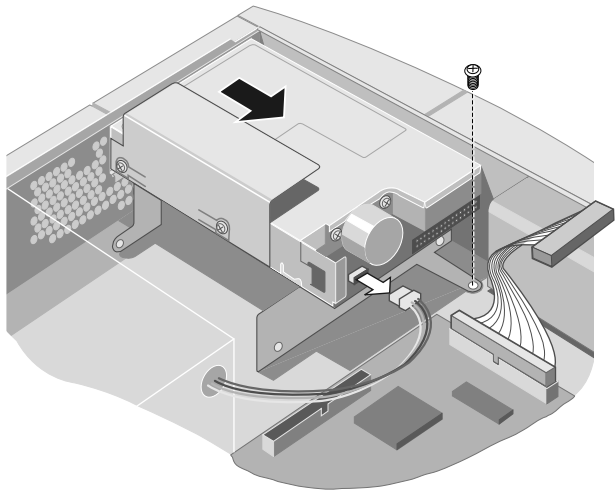

5. Secure the hard disk drive to the mounting bracket using the four fixing screws. Fit pair “A” first, then “B”.

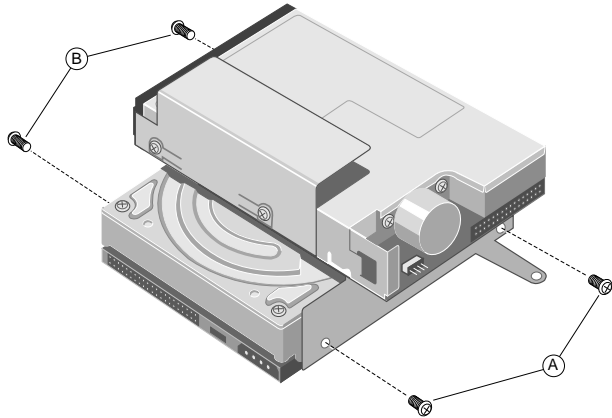

6. There should be three spare power cables coming from the power supply unit (including the one you disconnected from the diskette drive at Step 3). The cable with the largest connector is the hard disk drive power cable; connect it to the rear of the hard disk drive. The connector will only fit in one orientation.
7. Attach the signal cable to the rear of the hard disk drive. It's easier to attach the power and signal cables now, rather than later when the drive is in place.
8. Coax the mounting bracket and attached drives back into position and secure the bracket to the base of the system unit using the screw you removed at Step 4.
9. Attach the hard disk drive's signal cable to the motherboard.
10. Re-attach the diskette drive's signal and power cables.

Check your installation against the following illustration.

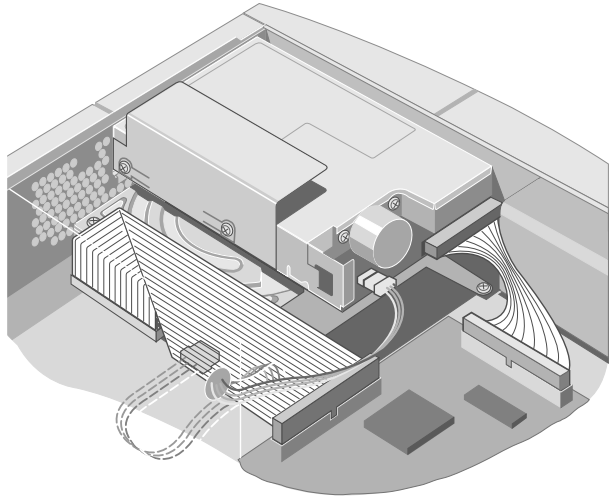

11. Replace the system unit cover.

### ***Adding both drives at once***

---

You may decide to upgrade a diskless system by adding a diskette drive and a hard disk drive at the same time. In this case you will need both upgrade kits.

The upgrade procedure is a combination of the procedures for diskette and hard disk drive separately (described above). In outline:

1. Turn off the computer and unplug all power cords.
2. Take suitable anti-static precautions and remove the system unit cover.
3. Uncover the diskette drive aperture.
4. Secure both drives to the mounting bracket.
5. Connect the hard disk drive's power and signal cables to the drive.

6. Coax the mounting bracket and attached drives into position and secure the bracket to the base of the system unit.
7. Connect the diskette drive's signal and power cables to the drive.
8. Connect both drives' signal cables to the motherboard.
9. Replace the system unit cover.



# A

## INSIDE THE SYSTEM UNIT

This appendix provides step-by-step instructions on obtaining access to the inside of the system unit for the purposes of maintaining or upgrading the system. Details of all relevant motherboard jumper settings are included.

---

### **Warning**

*Turn off the computer and unplug all power cords before removing the top cover.*

---

### **Anti-static precautions**

---

Static electricity can cause permanent damage to electronic components. You should be aware of this risk, and take precautions against the discharge of static electricity into your computer.

Anyone can generate static electricity by moving on a chair, brushing against desks or walls, or simply walking across an ordinary carpet. Items handed from one person to another, or being wrapped or unwrapped, can acquire a static charge. Air conditioning systems can also result in ambient static. Clothing made of synthetic fibres is particularly likely to generate static electricity; this static electricity is often completely unnoticed by the wearer, but can be sufficient to cripple or impair an electronic component.

Your computer is at risk from static discharge while the top cover is off. This is because the electronic components of the motherboard are exposed. Memory modules, cache upgrades and OverDrive processors are other examples of electrostatic sensitive devices (ESSDs).

All work that involves removing the cover must be done in an area completely free of static electricity. We recommend using a Special Handling Area (SHA) as defined by EN 100015-1: 1992.

This means that working surfaces, floor coverings and chairs must be connected to a common earth reference point, and you should wear an earthed wrist strap and anti-static clothing. It is also a good idea to use an ionizer or humidifier to remove static from the air.

When installing any upgrade, be sure you understand what the installation procedure involves before you start. This will enable you to plan your work, and so minimize the amount of time that sensitive components are exposed.

Do not remove the system unit cover, nor the anti-static bag or wrapping of any upgrade, until you need to.

Handle static-sensitive items with extreme care. Hold expansion cards and add-on components only by their edges, avoiding their electrical contacts. Never touch the components or electrical contacts on the motherboard or on expansion cards. In general, do not handle static-sensitive items unnecessarily.

Keep all conductive material, and food and drink, away from your work area and the open computer.

## ***Opening the system unit***

---

To remove the system unit cover:

1. Turn off both the system unit and the monitor.
2. If your AC power outlets have switches, set them to their Off positions.
3. Unplug all power cords from rear of the system unit.
4. Remove the two screws that secure the top cover.
5. Grasp the handle beneath the security loop and tug it rearwards slightly to loosen the top cover, then lift the top cover off.



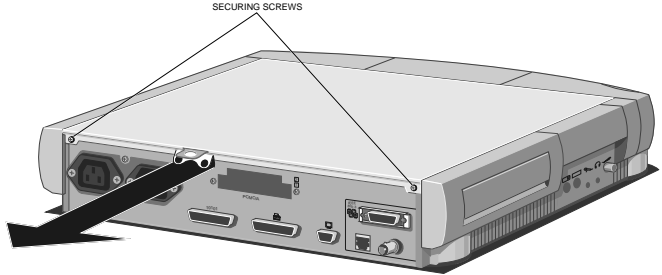

Refitting the cover is the reverse of removal. Take effective anti-static precautions while the top cover is off.

## Changing jumper settings

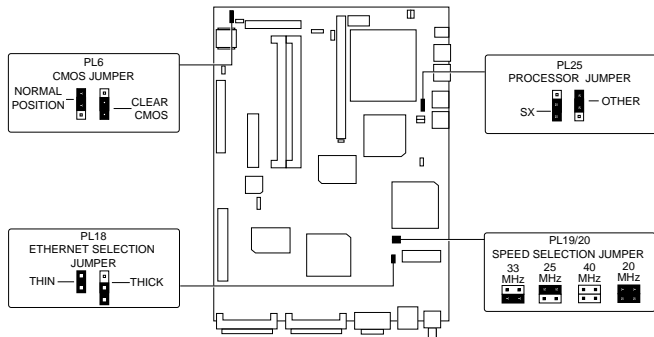

There are four jumpers on the motherboard that you may need to alter:

- Clear CMOS jumper
- Ethernet selection jumper
- Processor selection jumper
- Speed selection jumper

### Caution

Do **not** alter any other jumpers or switch settings. You may damage the system processor, the motherboard, or both. See the label on the inside of the system unit cover for up-to-date information.

### Jumper PL6 - Clearing CMOS memory

This jumper affects the CMOS memory and the security system.

In the “Normal” position, with pins 1 and 2 connected, the contents of CMOS memory, including the current security configuration, are maintained by the configuration battery.

In the “Clear CMOS” position, with pins 2 and 3 connected, CMOS memory is not maintained and its contents are lost after only a few seconds. The jumper can then be returned to the “Normal” position.

You may need to erase the security configuration if the Master user cannot logon. Before doing this, make sure you know the computer’s unique System Identification Number (SIN). The SIN provides a fail-safe mechanism in case the jumper is removed maliciously in an attempt to by-pass security. The SIN is normally printed on a label stuck onto the motherboard, but this label may have been removed as a security precaution. If the SIN label is missing, ask the person responsible for administering the security system for help.

When the computer is next turned on, several error messages will appear because of the missing configuration information. Once these have been acknowledged, the following dialog appears, requesting the SIN:



When you enter the SIN, the BIOS Setup utility is started automatically. Use the BIOS Setup utility to reconfigure the hardware as described in Chapter 3. Reconfigure and re-enable the security system as described in Chapter 6.

When you exit the BIOS Setup utility, the computer reboots automatically.

### ***Jumper PL18 - Selecting thick- or thin-Ethernet***

This jumper selects which Ethernet port to use. Only one port can be used at any one time. In the “Thin” position, with the two pins connected, you can use the thin-Ethernet BNC port. In the “Thick” position, with the pins disconnected, you can use the thick-Ethernet AUI (DIX) port. In either position, you can use the twisted-pair Ethernet port.

### ***Jumper PL25 - Selecting the processor type***

This jumper differentiates between different types of Intel processor. Use the “SX” position if the computer is fitted with an Intel486 SX. Use the “Other” position for any other supported Intel processor (for example, Intel486 DX or DX2, IntelDX4 or OverDrive).

### ***Jumper PL19/20 - Selecting the external clock speed***

This pair of jumpers sets the external clock speed for the system processor. This must be either 25 MHz or 33 MHz. Remember that the external clock speed is often only a fraction of the processor’s internal clock speed, which is usually the one advertised.

---

#### **Note**

*Apricot does not support the use of external clock speeds of 20 MHz or 40 MHz.*

---



## B

# TECHNICAL INFORMATION

This appendix provides some technical information about the computer. More detailed information is available from your supplier.

## Specifications

---

Processor	Types	Intel486 SX Intel486 DX Intel486 DX2 IntelDX4
	Clock speeds	25 MHz or 33 MHz
	Operating voltages	3.3 V or 5 V
BIOS ROM		256 Kb Flash
Memory	Motherboard	4 Mb 32-bit 70 ns
	Expansion	Two 32-bit 70 ns SIMMs (64 Mb maximum)
	External cache	256 Kbytes (optional)
Video	Controller	Cirrus Logic CL-GD543x/VL VESA local bus
	Video RAM	1 Mb or 2 Mb
	Resolutions	EVGA 1280 x 1024 EVGA 1024 x 768 SVGA 800 x 600 VGA 640 x 480
Network		PCnet-32 VESA local bus
Audio		Crystal Semiconductor CS4231
	Audio input	Microphone, line-in
	Audio output	Headphones, line-out
Security		Apricot LOC Technology v2.0
I/O ports	Dual Serial	25-way male D-type RS-232
	Parallel	25-way female D-type ECP/EPP compatible
Keyboard		102 key AT-compatible
Mouse		PS/2-compatible two-button
Diskette	Capacity	1.44 Mb
	Access time	94 ms (average)
Hard disk	Interface	IDE
	Form factor	3.5" x 1"
PCMCIA	Controller	Cirrus Logic CL-PD672x
	Sockets	2
	Slot 1	Type I, Type II or Type III card
	Slot 2	Type I or Type II card

## Physical characteristics

---

### Dimensions and weight

Component	Height	Depth	Width	Weight
System unit	70 mm	380 mm	380 mm	6.2 kg
Keyboard	40 mm	205 mm	488 mm	1.4 kg

### Temperature and humidity ranges

The computer is designed to operate in a normal office environment, but during storage and transportation the system is more tolerant of environmental factors.

Range	Temperature	Relative humidity with no condensation
Storage/Transport	0 to +65 °C	10% to 90%
Operational	0 to +35 °C	10% to 80%

## Electrical characteristics

---

### Voltage ranges

The PSU voltage range is initially set to that appropriate for the country in which the computer is first sold.

Switch setting	AC power supply (voltage and frequency)
115	100 - 120 volt AC, 50 - 60 Hz
230	220 - 240 volt AC, 50 - 60 Hz

The voltage range setting of the monitor must always agree with that of the system unit PSU.

### Power cords

The power cord supplied with the computer system unit complies with the safety standards applicable in the country in which it is first sold. If you wish to use the computer in

another country, you must ensure that you use a power cord which complies with the safety standards of that country.

Connect only manufacturer-approved monitors to the AC power outlet.

## Port characteristics

### Serial port

25-way male D-type (COM1/COM2)

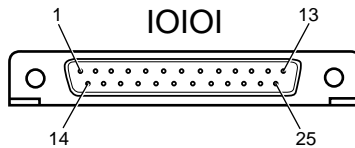

Pin	I/O	COM1/2	Function
1	-	-	Not connected
2	O	COM1	Transmit data
3	I	COM1	Receive data
4	O	COM1	Request to send
5	I	COM1	Clear to send
6	I	COM1	Data set ready
7	-	-	Signal ground
8	I	COM1	Data carrier detect
9	-	-	Not connected
10	-	-	Not connected
11	-	-	Not connected
12	I	COM2	Data carrier detect
13	I	COM2	Clear to send
14	O	COM2	Transmit data
15	-	-	Not connected
16	I	COM2	Receive data
17	-	-	Not connected
18	-	-	Not connected
19	O	COM2	Request to send
20	O	COM1	Data terminal ready
21	-	-	Not connected
22	I	COM1	Ring indicate
23	-	-	Not connected
24	-	-	Not connected
25	-	-	Not connected

**Parallel port**

25-way female D-type (LPT1)

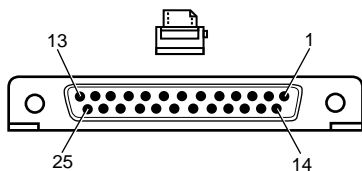

Pin	I/O	Function
1	I/O	-STROBE
2	I/O	Data bit 0
3	I/O	Data bit 1
4	I/O	Data bit 2
5	I/O	Data bit 3
6	I/O	Data bit 4
7	I/O	Data bit 5
8	I/O	Data bit 6
9	I/O	Data bit 7
10	I	-ACK
11	I	BUSY
12	I	PE
13	I	SLCT
14	O	-AUTO FEED
15	I	-ERROR
16	O	-INIT
17	O	-SLCT IN
18	-	Ground
19	-	Ground
20	-	Ground
21	-	Ground
22	-	Ground
23	-	Ground
24	-	Ground
25	-	Ground



**Monitor port**

15-way female D-type (VGA)

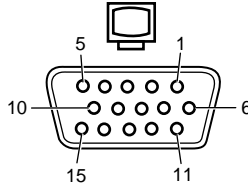

Pin	I/O	Output	Monochrome	Colour
1	O	Red	No pin	Red
2	O	Green	Mono	Green
3	O	Blue	No pin	Blue
4	-	Reserved	No pin	No pin
5	-	Digital G	Self test	Self test
6	-	Red Rtn	Key pin	Red Rtn
7	-	Green Rtn	Mono Rtn	Green Rtn
8	-	Blue Rtn	No pin	Blue Rtn
9	-	Plug	No pin	No pin
10	-	Digital G	Digital G	Digital G
11	-	Reserved	No pin	Digital G
12	-	Reserved	Digital G	No pin
13	O	Hsync	Hsync	Hsync
14	O	Vsync	Vsync	Vsync
15	-	Reserved	No pin	No pin

Red Rtn, Green Rtn, Blue Rtn = Analog grounds  
 Digital G = Digital ground for sync returns and self test.

### Keyboard and mouse ports

Both the keyboard and mouse ports accept 6-pin miniature DIN connectors. The voltages and signals are the same for both connectors.

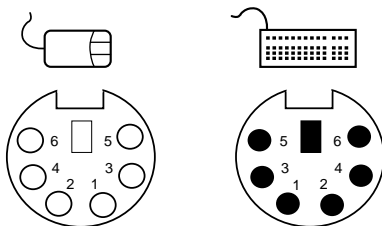

Pin	I/O	Function
1	I/O	Data
2	-	Reserved
3	-	Ground
4	-	+5 Vdc
5	I/O	Clock
6	-	Reserved

Although the keyboard and mouse ports are physically and electrically compatible, neither the keyboard nor the mouse will operate if plugged into the other's socket.

### BNC thin-Ethernet port

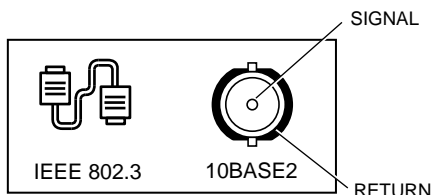

### AUI Thick-Ethernet port

The AUI (attachment unit interface) port is a 15-way female D-type connector. This connector is also sometimes referred to as a DIX port.

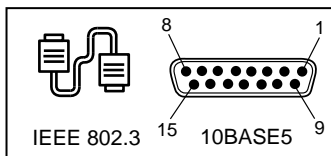

Pin	Function
1	Control in shield
2	Control in A
3	Data out A
4	Data in shield
5	Data in A
6	DC power common
7	No connection
8	No connection
9	Control in B
10	Data out B
11	Data out shield
12	Data in B
13	DC power +
14	Power shield
15	No connection

### TPE twisted-pair Ethernet port

RJ-45 connector.

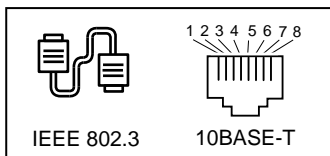

Pin	Function
1	Transmit data +
2	Transmit data -
3	Receive data +
4	Not used for 10Base-T
5	Not used for 10Base-T
6	Receive data -
7	Not used for 10Base-T
8	Not used for 10Base-T

### System resources

The computer's motherboard includes several standard devices—diskette and hard disk drive controllers, serial ports, and so on—plus integrated network, audio and PCMCIA systems.

Each of these requires certain system resources in order to function. Additional resources may be required by PCMCIA cards. These resources can include one or more of the following: interrupt request levels, DMA channels, input/output ports and space in the upper memory area. If necessary, unwanted motherboard components can be disabled by BIOS Setup to free resources (see Chapter 3).

#### Note

*With the advent of operating systems that support Plug and Play (PnP), there should be fewer conflicts between resources requested by PCMCIA cards and those used by motherboard components.*

## Interrupts

The *interrupt request level* or *IRQ* (the two terms are used interchangeably) is the line over which a device sends a signal to get the attention of, or interrupt, the processor.

Most of the computer's interrupts are reserved for motherboard components. Some of these interrupts are fixed, but others can be freed by disabling the component with BIOS Setup.

The following table shows the default assignment of interrupts in the computer and the possible choices available for the PCMCIA interface.

IRQ	Default assignment	IRQ defaults and options for PCMCIA
IRQ0	System counter	
IRQ1	Keyboard controller	
IRQ2	Slave interrupt controller	
IRQ3	Serial port 2 (COM2/4)	Option
IRQ4	Serial port 1 (COM1/3)	Option
IRQ5	PCnet-32 Ethernet adapter	
IRQ6	Diskette controller	
IRQ7	Parallel port	Option
IRQ8	Real time clock	
IRQ9	PCMCIA socket	Default
IRQ10	PCMCIA Card & Socket Services	Preferred
IRQ11	Enhanced Business Audio	
IRQ12	Mouse	
IRQ13	Coprocessor	
IRQ14	IDE hard disk controller	Option
IRQ15	PCMCIA socket	Default

Note that IRQ7 can usually be “double-booked” by the PCMCIA interface without affecting the operation of the parallel port. However, it is possible for software to enable the parallel port's use of IRQ7 (particularly in ECP/EPP modes), which may cause problems. If you have no intention of using the parallel port, you can disable it with the BIOS Setup utility, thereby freeing the interrupt.

### DMA channels

Some hardware devices can use a *direct memory access (DMA) channel* to access system memory without directly burdening the processor.

The following table shows the assignment of DMA channels. (The current PCMCIA standards do not allow PC Cards to use DMA channels.)

DMA	Assignment
DMA0	Enhanced Business Audio (capture)
DMA1	Enhanced Business Audio (playback)
DMA2	Diskette controller
DMA3	Enhanced Capabilities Port
DMA4	System
DMA5	
DMA6	
DMA7	

### I/O ports

*I/O ports* are used by the processor to communicate with hardware devices. Each port appears to the processor as an address low down in its address space, usually below 3FFh.

The following table shows the typical assignment of I/O ports:

I/O port	Typical assignment
000h-01Fh	DMA controller 1
020h-027h	Interrupt controller 1
030h-037h	Interrupt controller 1
040h-047h	System timer
050h-057h	System timer
060h-06Fh	Keyboard controller
070h-07Fh	Real time clock, NMI mask
080h-09Fh	DMA page register
0A0h-0BFh	Interrupt controller 2
0C0h-0DFh	DMA controller 2
0F0h, 0F1h	Math coprocessor
0F8h-0FFh	Math coprocessor
1F0h-1F8h	Hard disk drive controller

I/O port	Typical assignment
2F8h-2FFh	Serial port 2
308h-317h	Ethernet controller
388h-38Bh	FM synthesizer
3BCh-3BFh	Parallel port
3F0h-3F5h	Diskette drive controller
3F6h-3F7h	Hard disk drive controller
3F8h-3FFh	Serial port 1
534h-53Bh	Enhanced Business Audio
920h-927h	Motherboard control ports

### Upper memory area

The first megabyte (1024 kilobytes) of the computer's memory is divided into 640 kilobytes (Kbytes) of so-called *conventional memory* and 384 Kbytes of *upper memory*.

Part of the upper memory area is reserved for BIOS and video functions. Most of the remainder is usually claimed by Card & Socket Services to fulfil PCMCIA cards' requests for memory windows. Any remaining parts of upper memory can be allocated to device drivers and memory-resident programs as *upper memory blocks* or *UMBs*. (If you do not intend to use PCMCIA cards, you can un-install or disable Card & Socket Services and use all of the unused upper memory area for UMBs.)

The map on the next page shows the layout of the upper memory area.

---

#### Note

*Memory addresses are always written in base 16 or hexadecimal notation. Unlike the ten digits of the decimal system (0-9), hexadecimal uses sixteen digits (0-9 and A-F, where A=10, B=11, C=12 and so on up to F=15). Hexadecimal numbers are denoted either by the suffix "h" or by the prefix "0x". The final digit of a five-digit memory address is often omitted, so C8000h may be written as C800h. Since amounts of memory are usually stated as kilobytes rather than in hexadecimal notation, the following conversion table may be helpful:*

4 Kbytes = 1000h	32 Kbytes = 8000h
8 Kbytes = 2000h	64 Kbytes = 10000h
16 Kbytes = 4000h	128 Kbytes = 20000h

---

FFFFh	BIOS ROM (128Kb) BIOS Setup LOC Technology Ethernet RPL	The BIOS ROM is actually 256Kb but is paged
F8000h		
F0000h		
E8000h		
E0000h		
D8000h	PCMCIA Memory Windows or UMB space (96 Kb)	C8000h-C9000h (4Kb) for Card & Socket Services
D0000h		
C8000h		
C0000h	Video BIOS (32 Kb)	
B8000h	Video Memory (128Kb)	
B0000h		
A8000h		
A0000h		





# C

## QUICK GUIDE TO SECURITY

This computer is protected by an on-board security system. A **user account** has been set up so that you can use the computer, but you may be restricted to using it only at certain times or on certain days of the week - these are your **logon periods**.

The person responsible for the security system is called the **Master** user. This may be the owner of the computer, or someone else who has been given the job of safeguarding its security. If you have any problems with the security system, ask the Master user for help.

### **Logging-on to the computer**

Every time you turn on or restart the computer (for example, by pressing CTRL+ALT+DEL in MS-DOS) you can expect to go through a **logon sequence**. This typically involves an infrared device called a KeyLOC card, a user name and a password.

1. If the Logon dialog box appears, aim your KeyLOC card at the infrared sensor on the front of the computer and press the button on the card. If you don't have a KeyLOC card, press the ESC key instead.
2. If the User Logon dialog box appears, type your user name in the User Name box, press TAB, then type your password in the Password box. The password is not displayed as you type (each character is shown as an asterisk). Choose the OK button (if you press ENTER after typing your password, the OK button is chosen automatically).

You may get both dialog boxes, or only one. It depends on how the Master user has set up the security system.

①

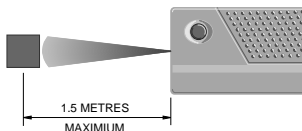
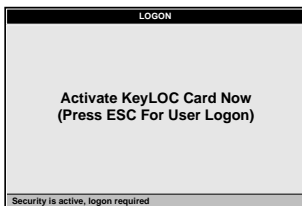

②



If the authentication you offer is correct, and provided that one of your logon periods is current, the computer boots normally and you are free to use the computer within the limits set out in your user account. Otherwise, the logon is invalid and the computer will not boot.

A **lockout period** may be imposed after three invalid logon attempts, and an alarm may sound after four invalid attempts. If a lockout is imposed, you will have to wait for it to end before you can try to logon again. Turning the computer off then on again will not cancel the lockout or the alarm.

## Changing your password

Depending on how security is configured, you may be able to change your password voluntarily when you logon.

1. After typing your user name and password in the User Logon dialog box, select the Change Password check box before choosing OK. The Change Password dialog box appears. (If it doesn't, you are not allowed to change your password.)

2. Type a new password in the New Password text box, and repeat it in the Confirm text box. A password can have up to eight characters, selected from A-Z, a-z, 0-9 and space. The security system may enforce a **minimum password length**.
3. Choose the OK button to make the change, or Cancel to keep your existing password. Any change you make will come into effect when you next logon.

If the security configuration includes a **minimum password lifetime**, you will not be allowed to change your password again until this lifetime has expired.

If the Password Expired dialog ever appears, the security system is forcing you to change your password because the **maximum password lifetime** has expired. This is necessary because the longer a password is in use, the greater the chance of it being discovered.

Don't choose a password that someone who knows you could guess. For example, avoid obvious choices such as your partner's name or your car registration number. Include a mixture of uppercase and lowercase letters, and numbers. Use made-up words that aren't in the dictionary. Never write your password down or tell anyone (including the Master user) what it is.

### Logon statistics

When you logon, some **logon statistics** are displayed, for example:

No of valid logons 11, Last valid logon 21-09-94  
No of invalid logons 2, Last invalid logon 04-09-94

The number of valid and invalid logons, and the last invalid logon date, are statistics that are the same for all users. The **last valid logon** relates only to you; it records the last date on which you (or someone using your user account) logged on. These statistics can be reset from time to time by the Master user.

### Variations in the logon sequence

There are some possible variations in the logon sequence, depending on the details of the security configuration:

- There is an optional feature known as **Quick Logon**. If this feature is enabled, you will not have to go through the logon sequence every time you want to use the computer. Instead, either a Logon button appears in the startup dialog, or the following message is displayed:

Press ALT+L for Logon Sequence

If you choose the Logon button or press ALT+L within 2 seconds of this message appearing, the logon sequence is started as described earlier. If you do nothing, you will be automatically logged-on using a "standard" or "default" user account.

- The Master user may have decided to disable the alarm and/or set a null lockout period. If no lockout period is specified, the system allows unlimited logon attempts.

### ***Unattended mode for Microsoft Windows***

An optional enhancement to the security system called **LOC Saver** offers an **unattended mode** for the Microsoft Windows operating system. When leaving the computer unattended for a time, you can click the button on your KeyLOC card to obscure the screen and lock the keyboard and mouse; Windows continues working “behind the scenes”. When you return, another click of the button cancels unattended mode. Ask the Master user if the computer has this feature.

Remember, if there’s anything about the security system you don’t understand, ask the Master user.

apricot

 MITSUBISHI ELECTRIC

APRICOT COMPUTERS LIMITED  
3500 PARKSIDE  
BIRMINGHAM BUSINESS PARK  
BIRMINGHAM B37 7YS  
UNITED KINGDOM

APRICOT COMPUTERS LIMITED  
TRAVELLERS LANE  
HATFIELD  
HERTFORDSHIRE AL10 8XB  
UNITED KINGDOM

MITSUBISHI ELECTRIC EUROPE GmbH  
GOTHAER STRASSE 8  
POSTFACH 1548  
40835 RATINGEN  
DEUTSCHLAND