



APRICOT PCs & SERVERS

# Apricot LS SERIES

Owner's Handbook



Certificate No.'s:

FM 1716 FS 21715 FS 30305

# **APRICOT LS SERIES**

*with Pentium®II processor*

# **OWNER'S HANDBOOK**

Intel and Pentium®II are registered trademarks of Intel Corporation.

Microsoft, MS-DOS, Windows®95 and Windows®NT are registered trademarks of Microsoft Corporation in the US and other countries.

Other trademarks mentioned within this document and not listed above are the properties of their respective owners.

Information contained in this document is subject to change without notice and does not represent a commitment on the part of Apricot Computers Limited. Any software described in this manual is furnished under a license agreement. The software may be used or copied only in accordance with the terms of this agreement. It is against the law to copy any disk supplied for any purpose other than the purchaser's personal use.

No part of this manual may be reproduced or transmitted in any form or by any means electronic or mechanical including photocopying and recording, for any purpose, without the express written permission of the publishers.

Copyright © Apricot Computers Limited 1997. All rights reserved.

Published by:  
Apricot Computers Limited  
3500 Parkside  
Birmingham Business Park  
Birmingham, England  
B37 7YS

---

<http://www.misubishi-computers.com>



APRICOT PCs & SERVERS

Printed in the United Kingdom

# CONTENTS

## **Safety and Regulatory notices**

---

General	i
Maintenance and Transporting	iii
Standards and Legalities	iv
Power connection	v

## **1 Welcome**

---

Unpacking	1/1
Pictorial guide to the system unit	1/2
General advice	1/6
Connecting the components	1/7

## **2 Getting Started**

---

Turning on the computer	2/1
Power saving	2/2
Shutting down the computer	2/3
Using the computer for the first time	2/4
<b>Electronic Fingerprinting</b>	2/5
Backing-up the pre-installed software	2/6
Improving your display settings	2/7
If your hard disk is larger than 2 gigabytes	2/8

## **3 Diskettes and CDs**

---

Diskette drive	3/1
CD-ROM drive	3/3

## Contents

<b>4</b>	<b>Expansion Cards</b>	
	Configuring the card	4/2
	Installing the card	4/5
	Reserving ISA legacy resources	4/7
	Telling Windows about the new hardware	4/7
<b>5</b>	<b>Motherboard Features &amp; Upgrades</b>	
	Motherboard layout and features	5/2
	Motherboard IRQs and DMA channels	5/6
	Replacing the configuration battery	5/7
	Adding more memory	5/8
	Adding more video memory	5/12
	The processor assembly	5/13
<b>6</b>	<b>Hard Disk Upgrades</b>	
	Configuring the drive	6/1
	Installing the drive	6/2
	Partitioning and formatting the drive	6/4
<b>7</b>	<b>BIOS Setup &amp; POST</b>	
	BIOS Setup	7/2
	Power-on self-test	7/4
<b>8</b>	<b>Troubleshooting</b>	
	Problems when starting	8/1
	Common problems	8/3
	<b>Equipment Log</b>	

# SAFETY AND REGULATORY NOTICES

## General

---

### Electrical

#### **The computer uses a safety ground and must be earthed.**

The system unit AC power cord is its 'disconnect device'. Ensure that the system unit is positioned close to the AC power outlet and that the plug is easily accessible.

The power cord packed with the computer complies with the safety standards applicable in the country in which it is first sold. Use only this power cord. Do not substitute a power cord from any other equipment.

To prevent fire and electric shock, do not expose any part of the computer to rain or moisture. Turn off the computer and unplug all power cords before moving or cleaning the system unit, or removing the system unit top cover.

### Battery

#### **This product contains a lithium battery.**

Do not use a metal or other conductive implement to remove the battery. If a short-circuit is made between its positive and negative terminals the battery may explode.

Replace a discharged battery with one of the same type; another type may explode or ignite. Follow the instructions contained in the *Owner's Handbook* to replace the battery. Dispose of a discharged battery promptly and in accordance with the battery manufacturer's recommended instructions. Do not recharge, disassemble or incinerate the discharged battery. Keep away from children.

### Laser products

Any CD-ROM drive fitted in this system is classified as a CLASS 1 LASER PRODUCT according to IEC825 *Radiation Safety of Laser Products (Equipment Classification: Requirements and User's Guide)*. The CLASS 1 LASER PRODUCT label is located on the underside of the system unit.

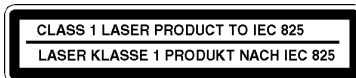

The CD-ROM drive contains a laser system which is harmful to the eyes if exposed. Do not attempt to disassemble the CD-ROM drive; if a fault occurs, call an authorised maintainer.

Use the CD-ROM drive only as described in this manual. Failure to do so may result in exposure to hazardous radiation.

# SAFETY & REGULATORY NOTICES

## **Ergonomic**

When positioning the system unit, monitor and keyboard, take into account any local or national regulations relating to ergonomic requirements.

## **Anti-static precautions**

---

### **WARNING**

*Static electricity can cause permanent damage to electronic components. You should be aware of this risk, and take precautions against the discharge of static electricity into the computer.*

---

The computer is at risk from static discharge while the top cover is off. This is because the electronic components of the motherboard are exposed. Memory modules, expansion cards and replacement processors are examples of electrostatic sensitive devices (ESSDs).

All work that involves removing the cover must be done in an area completely free of static electricity. We recommend using a Special Handling Area (SHA) as defined by EN 100015-1: 1992. This means that working surfaces, floor coverings and chairs must be connected to a common earth reference point, and you should wear an earthed wrist strap and anti-static clothing. It is also a good idea to use an ionizer or humidifier to remove static from the air.

When installing any upgrade, be sure you understand what the installation procedure involves before you start. This will enable you to plan your work, and so minimise the amount of time that sensitive components are exposed.

Do not remove the system unit cover, nor the anti-static bag or wrapping of any upgrade, until you need to.

Handle static-sensitive items with extreme care. Hold expansion cards and add-on components only by their edges, avoiding their electrical contacts. Never touch the components or electrical contacts on the motherboard or on expansion cards. In general, do not handle static-sensitive items unnecessarily.

Keep all conductive material, and food and drink, away from your work area and the open computer.

## **Thermalcote bonding compound**

The thermal bonding compound used between the system processor and its heat sink can cause skin irritation and stain clothing. Avoid prolonged or repeated contact with skin. Wash thoroughly with soap and water after handling. Avoid contact with eyes and inhalation of fumes. Do not ingest.

# SAFETY & REGULATORY NOTICES

## Maintenance

---

Switch off and disconnect all cables before attempting to clean the computer.

Do not use sprays, solvents or abrasives that might damage the system unit surface. Do not use cleaning fluids or sprays near air vents, ports, or the diskette and CD-ROM drives.

Occasionally wipe the system unit with a soft, slightly damp, lint-free cloth.

Occasionally wipe over the air vents on the rear and sides of the system unit. Dust and fluff can block the vents and limit the airflow.

Occasionally clean the diskette and CD-ROM drives using a proprietary head cleaner.

Occasionally wipe the monitor with a soft, slightly damp, lint-free cloth. It is best to use anti-static glass cleaner on the monitor screen, but do not spray glass cleaner directly onto the screen; it could run down inside the case and damage the circuitry.

## Transporting

---

Use common sense when handling the computer; hard disks in particular can be damaged if the computer is dropped or handled roughly. As a precaution, back up the contents of the hard disks to tape or diskettes before moving the computer.

Switch off and disconnect all cables before attempting to move the computer, particularly do not try to move the computer while it is plugged into the AC power supply.

When lifting and carrying the computer, use the metal sides of the system unit and never attempt to lift the system unit with a monitor still on top.

If you need to transport the computer any great distance, use the original packing materials.

If you are planning to use the computer in another country, it may not be suitable, check with your supplier, particularly on the availability of the correct AC power cords.

---

### NOTE

*Any existing maintenance or warranty agreement may not be supportable in another country. The system may have to be returned to the supplier.*

---



# SAFETY & REGULATORY NOTICES

## Standards

---

### Safety

This product complies with the International safety standard IEC950 and the European safety standard EN60950 which will, when applicable, include the national deviations for the country in which it is sold.

### Electro-magnetic Compatibility (EMC)

This product complies with the following European EMC standards:

Emissions EN50022 Class B

Immunity EN50082-1

This product also complies with the following International EMC standards:

VCCI Level 1 (Japan)

### Notes

All interconnecting cables (for example, signal and communication cables) should be less than 2 metres in length. If cable extensions are used, ensure adequate earth connections are provided and screened cables are used.

If any metal casework components are removed, during upgrade work for example, ensure that all metal parts are correctly re-assembled and all internal and external screws are re-fitted and correctly tightened.

## Legalities

---

This equipment complies with the relevant clauses of the following European Directives (and all subsequent amendments):

Low Voltage Directive	73/23/EEC
EMC Directive	89/336/EEC
Telecommunications Directive	91/263/EEC
CE Marking Directive	93/68/EEC

### IMPORTANT

*This system complies with the CE Marking Directive and its strict legal requirements. Use only parts tested and approved by Mitsubishi Electric PC Division. Failure to do so may result in invalidating both the compliance and your warranty. All expansion cards, drives and peripherals must carry the CE mark to ensure continued compliance.*

---

# SAFETY & REGULATORY NOTICES

## Power Connection

---

### Typical AC plugs

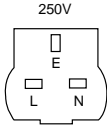

**BS1363A**

U. K.

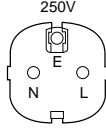

**SHUCO**

Austria Belgium

Finland France

Italy Germany

Sweden Norway

Holland

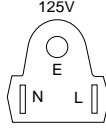

**NEMA 5-15P**

Taiwan

Thailand

Japan

USA

Canada

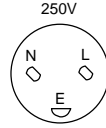

**SRAF 1962/DB16/87**

Denmark

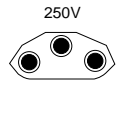

**ASE 1011**

Switzerland

### Checking the AC power supply

When this product is delivered, it is ready for the commercial AC power supply generally available in the country in which it is first sold. It has been set for the correct voltage range, and is supplied with an AC power cord and plug which comply with the relevant safety standards.

Before using the product in a country other than that in which it was originally sold, you must check the voltage and frequency of that country's AC power supply, and the type of power cord required there. Check the power rating labels on the rear of the computer's system unit and its monitor to ensure that they are compatible with the AC power supply.

The computer can function within two alternative AC power supply ranges, according to the position of the voltage selection switch on the rear of the system unit:

#### **Switch setting    AC power supply (voltage and frequency)**

---

115                      100 - 120 volt AC, 50 - 60 Hz

230                      200 - 240 volt AC, 50 - 60 Hz

The voltage setting of the monitor must always be the same as the voltage setting of the system unit. See the *User's Guide* that accompanies the monitor or consult your supplier to find out how to change the voltage setting.

---

### **CAUTION**

*It is imperative that the computer is set to the correct voltage range before use. If not, the machine may be irreparably damaged.*

---

# SAFETY & REGULATORY NOTICES

## Connecting to the AC power supply

---

### IMPORTANT

*Any peripheral equipment that requires an AC power cord must be earthed.*

---

Use the following guidance to connect the components together. It is important that you take each step in the order indicated.

1. Before connecting any components, ensure that the AC power supply is switched off or disconnected, and that the system unit, the monitor, and any peripherals are turned off.
2. Connect the component signal cables to their respective ports on the system unit: keyboard, mouse, monitor, audio (where appropriate) and any other peripherals.
  - ◇ Where appropriate, connect the computer to the network.
3. Connect the component power cords: system unit, monitor to system, plus any other peripherals to nearby, grounded AC power outlets. (Never substitute a power cord from any other appliance). Then switch on or connect the AC power supply.
4. Turn on the system unit first, then the monitor, then other peripherals.

## Power Cable Connections - UK ONLY

This equipment is supplied with an AC power cord that has a non-removable moulded plug.

Always replace the fuse with one of the same type and rating which is BSI or ASTA approved to BS1362. Always refit the fuse cover, never use the plug with the fuse cover omitted.

## External Speakers (where supplied)

Always switch off or disconnect the AC supply before disconnecting any of the speaker leads, whether audio or power. Disconnect the AC supply from the speaker power unit when not in use for any period of time.

To prevent the risk of electric shock, do not remove speaker covers.

Connecting the speaker power cord to any other cords or joining cords together can cause fire and risk of electric shock.

# 1

# WELCOME

This chapter gives you a quick tour of your new Apricot LS Personal Computer. As soon as you've unpacked the components and assembled them, you should progress to the next chapter, *Getting Started*.

Throughout this manual 'Windows' means Microsoft Windows 95 or Windows NT 4.x, unless otherwise stated.

---

## WARNING

*Read the Safety & Regulatory Notices section at the start of this manual before using the computer for the first time.*

---

## Unpacking

---

After unpacking your computer, keep all the cartons, boxes and packaging materials; you will need them again if you have to transport the computer elsewhere.

Use the page at the end of this manual to make a note of the manufacturer's data recorded on the various components (product codes, serial numbers, etc.). A service engineer may need this information if the computer develops a fault.

## Pictorial guide to the system unit

---

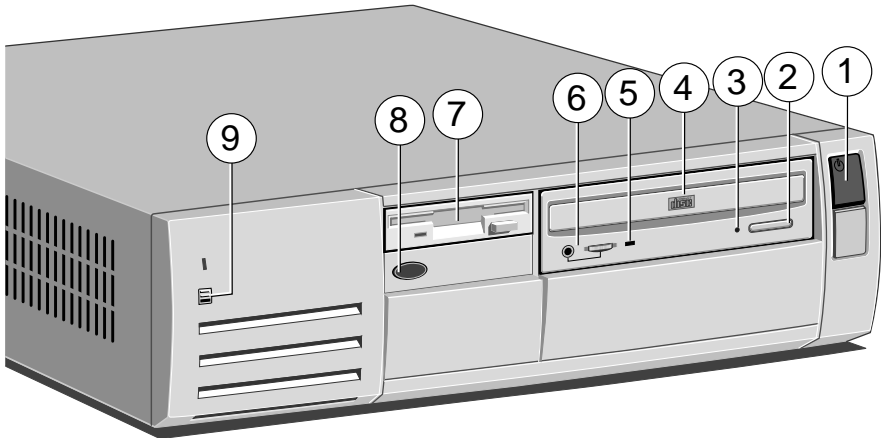

- |   |                              |   |                                |
|---|------------------------------|---|--------------------------------|
| 1 | POWER button                 | 6 | CD phono jack & volume control |
| 2 | CD EJECT button              | 7 | Diskette drive                 |
| 3 | CD emergency eject hole      | 8 | Infrared sensor (optional)     |
| 4 | CD-ROM disc drawer (platter) | 9 | Hard disk activity indicator   |
| 5 | CD activity indicator        |   |                                |

Use the POWER button to turn on the computer and change power modes. The light on the button changes colour to show the current mode. See the *Getting Started* chapter for more information.

Not all systems are fitted with a CD-ROM drive.

The infrared sensor is present only on models fitted with a LOC Technology system in the form of an Apricot LS Security Card. See the *LOC Technology Master User's Guide* for more information.

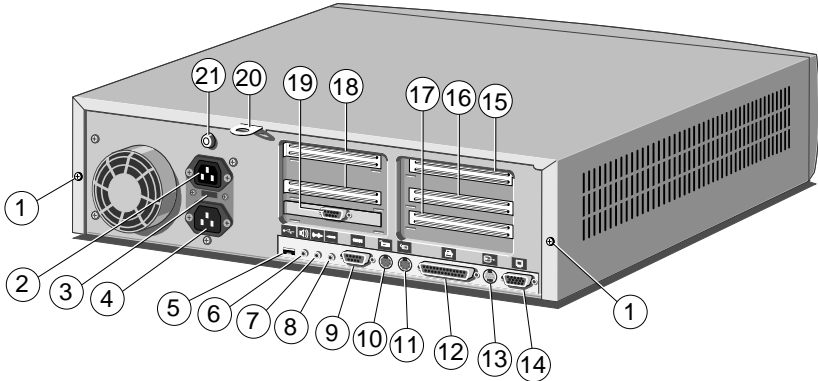

- |   |  |
|---|--|
| <ul style="list-style-type: none"> <li>1 Casing screws for the top cover</li> <li>2 AC power outlet for monitor</li> <li>3 Voltage selection switch</li> <li>4 AC power inlet from AC supply</li> <li>5 Double USB port</li> <li>6 Audio output (speaker) jack</li> <li>7 Audio line-out jack</li> <li>8 Microphone input jack</li> <li>9 Serial (modem) port 1</li> <li>10 PS/2 keyboard port</li> <li>11 PS/2 Mouse port</li> </ul> | <ul style="list-style-type: none"> <li>12 Parallel (printer) port</li> <li>13 Video out port (option)</li> <li>14 Monitor port</li> <li>15 PCI slot (full-length)</li> <li>16 ISA slot (full-length)</li> <li>17 ISA slot (half-length)</li> <li>18 PCI slots (two half-length)</li> <li>19 Serial port 2 (optional)</li> <li>20 Security loop for cable or padlock</li> <li>21 Caselock (key supplied)</li> </ul> |
|---|--|

The audio input socket is mainly intended for a microphone. Alternatively, you could attach a personal stereo (tape or CD). The socket provides “phantom power” for electret condenser type microphones.

The audio output socket is intended for headphones or a pair of external self-powered loudspeakers.

### Rear port symbols (from above illustration)

5	6	7	8	9	10	11	12	13	14
USB	Speaker	Line out	Mic.	COM1	Key'bd	Mouse	Print	Video	Mon.

**To remove the system unit cover**

1. Shut down the computer and turn off the monitor.
2. If your AC power outlets have switches, set them to their off positions.
3. Unplug all power cords from the rear of the system unit.
4. Turn the caselock key to the unlocked position.
5. Unfasten the two casing screws.
6. Slide the top cover rearwards slightly, then lift it off.

Refitting is the reverse of removal. Take effective anti-static precautions while the top cover is off, as explained in the *Safety & Regulatory Notices* at the start of this manual.

Some Apricot LS models incorporate a security feature, controlled in BIOS Setup, that can detect if the top cover has been removed while the computer was turned off. See the on-line help in BIOS Setup for more information.

See the chapter on *Motherboard Features & Upgrades* for more information about the motherboard.

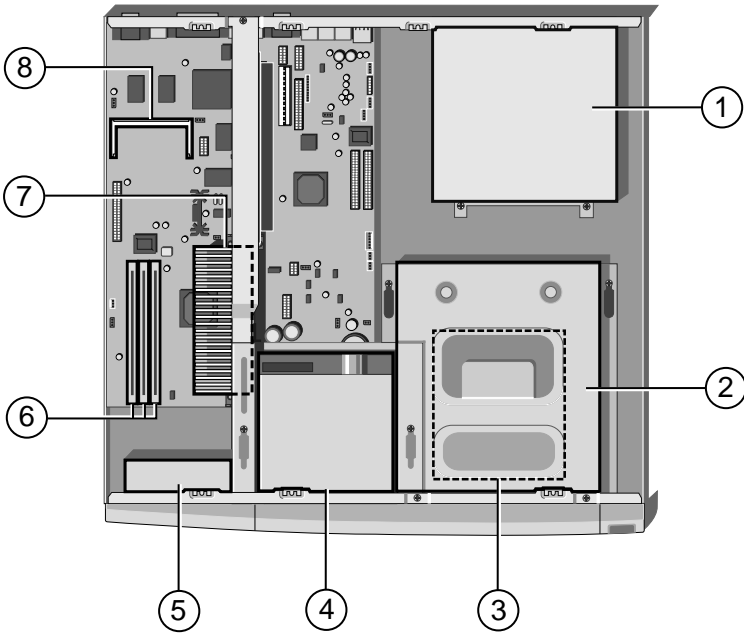

- 1 Power supply
- 2 CD-ROM (optional) housing
- 3 Hard disk drive housing (under CD-ROM)
- 4 Floppy diskette drive
- 5 Case fan\*
- 6 Memory (DIMM) sockets
- 7 Pentium® II processor
- 8 Video memory (SoDIMM) socket

\* The fan speed and thus system noise, can vary. The fan is controlled by a temperature sensor on the processor, which gets warmer during some operating conditions, such as intensive software usage.



## General advice

---

This computer is designed to be used in a normal home or office environment. Here are a few hints for choosing a suitable site:

- ◆ Place the system unit flat on a sturdy, level surface, free from vibration.
- ◆ Site the computer away from moisture, direct sunlight, and extremes of heat and cold. Avoid situations in which the surrounding temperature or humidity may change rapidly. When the computer is in use, the temperature should be between 10 and 35 °C and humidity between 20% and 80% (with no condensation).
- ◆ When positioning the system unit, monitor and keyboard, take into account any local or national regulations relating to ergonomic requirements. For example, you should ensure that little or no light is reflected off the monitor screen as glare, and that the keyboard is placed in a comfortable position for typing.
- ◆ Give the computer plenty of room so that air can circulate on all sides. Air is drawn into the system unit through vents at the front and on the left-hand side, and expelled through the vent on the back. Ensure that these vents are never obstructed.

Do not allow any cables, particularly power cords, to trail across the floor where people walking past can snag them.

---

### WARNING

*The computer uses the system unit AC power cord as its 'disconnect device'. Ensure that the system unit is positioned close to the AC power outlet, and that the plug is easily accessible.*

*To prevent fire and electric shock, do not expose any part of the system unit to rain or moisture.*

---

## Connecting the components

---

Use the following guidance to connect the components together. It is important that you take each step in the order indicated.

1. Before connecting any components, ensure that the AC power supply is switched off or disconnected, and that the system unit, the monitor, and any peripherals are turned off.
2. Connect the components' signal cables to their respective ports on the system unit: keyboard, mouse, monitor, audio (where appropriate) and any other peripherals. Where appropriate, connect the computer to the network.
3. Connect the components' power cords: monitor to system unit, and system unit and any other peripherals to nearby, grounded AC power outlets. Then switch on or connect the AC power supply.

With AC power applied, the system unit is usually in Off [*red*] mode. See the *Getting Started* chapter for more information about power modes.

Some Apricot LS models incorporate a feature, controlled in BIOS Setup, that automatically boots the PC to On [*green*] mode if AC power is restored, for example, after a power failure. See the on-line help in BIOS Setup for more information.

---

### COMPUTER POWER ON/OFF

*The push-button on/off power switch on the front panel of the computer does not completely remove (turn off) the AC power to the computer. To completely remove AC power from the computer, unplug the AC power cord from the power supply or the wall outlet.*

---

## 2 GETTING STARTED

You should read this chapter even if you do not read any other. It provides important information to help you to use your Apricot PC safely and efficiently.

### **Turning on the PC**

---

To turn on the computer, simply press the POWER button. The colour of the indicator on the POWER button turns from [*red*] to [*green*]. Remember that the monitor has its own power button or switch; see the monitor's *User Guide* for details.

#### **Power-on self-test (POST)**

Whenever the computer is turned on, a power-on self-test (POST) routine test various hardware components, and compares the actual configuration of the computer with that recorded in its permanent memory. During this time, BIOS sign-on and POST messages may be displayed. These messages are not significant unless they report errors – see the *BIOS Setup & POST* chapter.

#### **Booting the operating system**

Provided that POST succeeds without discovering any serious errors or configuration discrepancies, the computer attempts to find an operating system; that is, it attempts to 'boot'.

Apricot PCs are typically supplied with either Windows 95, Windows NT or MS-DOS/Windows for Workgroups already in place or 'pre-installed' on the hard disk, so that the operating system is ready for you when you turn on the computer.

---

#### **NOTE**

*If a diskette is in the diskette drive when the computer is turned on, the computer will attempt to boot using that diskette. This will succeed only if the diskette is a 'system diskette'; that is, one bearing at least the rudiments of an operating system.*

---

### Power saving

---

Use the POWER button to turn the computer on and change power modes. The colour of the indicator light on the POWER button shows the current power mode:

[red]      **Off.** Your computer is turned off, but is still connected to the AC power supply, ready to be turned on (or turn itself on) when needed.

[yellow]    **Suspend.** Your computer is “sleeping” to conserve electricity. The processor stops, the hard disk stops spinning and the monitor goes blank. Briefly pressing the POWER button wakes it up again. (This mode is not available with Windows NT 4.x.)

[green]     **On or Standby.** Your computer is awake and working. During periods of inactivity the PC automatically reduces the power consumption of idle components (Standby). For example, the monitor screen may go blank. Move the mouse or press any keyboard key to wake up the PC again.

In Suspend mode your computer complies with the requirements of the “Energy Star” programme for energy-saving systems. In Standby mode your computer does its best to minimise power usage but may not always reach Energy Star levels.

Using the BIOS Setup utility, you can tell the computer to wake itself up from Suspend or Off mode at a certain time or, if a suitable modem is installed, when an incoming call is received. A networked computer can also be woken up by remote control, if it is fitted with a network card that supports IBM’s “Wake On LAN” technology.

#### Manual power saving

If you press the POWER button while the PC is On [green] and running either Windows 95 or Windows for Workgroups, the PC goes into Suspend [yellow] mode. You have to press the POWER button to return to On [green] mode – just moving the mouse or using the keyboard won’t work.

Alternatively, in Windows 95 (or later) you can click the **Start** button in the taskbar, then click **Suspend**.

---

**NOTE**

*Future versions of Windows will allow you to redefine the POWER button so that when you press it the operating system shuts down and the PC goes directly into Off mode.*

---

**Automatic power saving**

If you leave your PC running Windows 95 or Windows for Workgroups without doing anything, it moves automatically through Standby [*green*] to Suspend [*yellow*] mode. Press the POWER button to wake it up again.

You can turn off Automatic Power Saving in the BIOS Setup utility; see the *BIOS Setup & POST* chapter for more information.

---

**CAUTION**

*The monitor supplied with your computer is designed to recognise these energy-saving modes. If you want to use another monitor, make sure that it supports the VESA standard for "Display Power Management Signalling"; if it doesn't, it may be permanently damaged.*

---

## Shutting down the PC

---

To shut down the computer safely, do the following:

1. Wait until all the activity indicators on the front bezel show 'not busy'.
2. Turn off any attached peripherals, except for the monitor and other peripherals that are designed to be kept on permanently.
3. According to your operating system:
  - ◇ In Windows 95 or Windows NT 5.x, click the **Start** button in the taskbar, then click **Shut Down**. Select **Shutdown the computer** and click **Yes**. (You do *not* have to press the POWER button.)
  - ◇ In Windows NT 4.x, click the **Start** button in the taskbar, then click **Shut Down**. Select **Shutdown the computer** and

## Getting Started

click **Yes**. When told that it is safe to do so, press the POWER button to turn off the computer.

- ◇ In Windows for Workgroups, click the **File** menu in Program Manager, then click **Exit Windows**. Once back in MS-DOS, press the POWER button.
- ◇ In MS-DOS, or during POST, press the POWER button.

After you shut down the PC, wait at least 5 seconds before turning it on again. The computer may not initialise itself properly if you turn it off then on again in quick succession.

### **Emergency shut down**

In exceptional circumstances, you can put your PC into Off [*red*] mode without shutting down Windows first. To do this, press and hold down the POWER button for at least four seconds.

If you press the POWER button while the PC is running MS-DOS or performing the power-on self-test (POST), the PC *always* goes directly into Off [*red*] mode.

---

### **CAUTION**

*In an emergency shut down, you may lose any recent changes made to the files you are currently working on.*

---

## **Using the computer for the first time**

---

### **First time with Windows 95 or Windows NT**

The first time you turn on your computer you must tell Windows your name (and the name of the company for which you work, if applicable) and agree to the legal terms and conditions of the Windows Licence Agreement. Windows then spends a few minutes analysing your computer and configuring itself to take full advantage of your computer's components. Windows 95 also offers you the opportunity to install a printer and make back-up diskettes of Windows and other pre-installed software. Note that you do not have to install a printer or make back-up diskettes at this time if you don't want to. See the section on "Backing-up the pre-installed software" later in this chapter.

### **First time with Windows for Workgroups**

The first time you turn on your computer a message appears explaining the legal terms and conditions that govern the use of the software pre-installed on the computer's hard disk. Once you have read this message, you can press the F3 key to continue. By doing so you are acknowledging that you have read, understood and accepted the terms and conditions.

## **Electronic Fingerprinting**

---

Electronic Fingerprinting allows you to 'brand' your computer by storing personal information in its permanent memory. If you include your name, address and phone number this will aid the police if your computer is stolen.

The Apricot Electronic Fingerprinting program appears every time you start Windows until you have branded the computer. If you don't brand your computer promptly, someone else might do it first.

After you have entered your details you are prompted to set a 'branding password'. This password will be requested if you ever need to run the Electronic Fingerprinting program again to change the branding information (for example, if you change address). Optionally, for extra security, you can decide that this same password is requested every time the computer is turned on, or every time the AC power supply is interrupted.

If you forget your branding password, you can use a special 'fall-back password' instead. The fall-back password is a 12-digit number that is unique to your computer. It is displayed once, the first time you set a branding password.

---

### **IMPORTANT**

*The fall-back password is displayed only once. You must make a note of the password immediately, because you will never see it again. There is a page at the end of this manual where you can write it down.*

---

If you decide to use the branding password to control access to your computer, don't set up "password on boot" in the BIOS Setup

utility as well, or both passwords will be requested every time the computer is turned on (branding password first, then the supervisor password).

---

### CAUTION

*Do not turn off the computer while using the Electronic Fingerprinting program. It might corrupt your computer's BIOS.*

---

## **Backing-up the pre-installed software**

---

Apricot PCs arrive with a pre-installed copy of Windows 95, Windows NT or Windows for Workgroups. Additional software may be pre-installed at the factory or by your Mitsubishi Electric PC supplier.

We recommend that you copy or 'back-up' any pre-installed software soon after setting up the system. This is particularly important for systems that are supplied without installation diskettes for the software on the hard disk. A back up copy will safeguard the pre-installed software against loss if the hard disk fails or if you accidentally overwrite or delete files.

- ◆ The Microsoft Create System Disks utility (Windows 95) or the Apricot Disk Maker utility (Windows NT or Windows for Workgroups) allows you to create installation diskettes from disk images pre-installed on the hard disk. See the utility's on-line help for more information.
- ◆ To back up other pre-installed software (and your own files) use the Backup tool (Windows 95 and Windows NT) or Backup for Windows (Windows for Workgroups).

In general, any copy you make of pre-installed software must be used only as a back-up copy, in case the pre-installed version is lost. You are **not** allowed to use installation diskettes created from disk images to install the software onto another computer.

Some of the software may have been supplied "pre-configured" for your PC's actual setup, for example, video drivers. It may not work on another PC and may even cause serious problems.



## **Improving your display settings**

---

Your pre-installed copy of Windows is configured for a standard monitor setting (640 x 480 pixels in a maximum of 16 different colours), so that Windows is sure to display correctly whatever monitor you have.

Most modern monitors, including Mitsubishi Electric monitors, can display higher resolutions than standard VGA. You can change the setting to one that more closely matches your own monitor, to get the best performance from it.

### **Display settings in Windows 95 or Windows NT**

The monitor setting is changed by using the Change Display Type option on the Settings tab of the Display Properties dialog. This option offers a list of major monitor manufacturers and models, including all current Apricot monitors. See Windows' Help for instructions on changing display settings.

---

#### **TIP**

*To view the Display Properties dialog, right-click with the mouse while pointing at the background area of the Windows desktop, then select Properties from the pop-up menu.*

---

### **Display settings in Windows for Workgroups**

The monitor setting is changed by using the ATI Desktop utility in the Apricot group. Open ATI Desktop, choose Screen Adjustment, then choose Select Monitor. This offers a list of all current Apricot monitors. Once you have selected the correct monitor, you can select the required resolution. See ATI Desktop's on-line help for more information.

## **If your hard disk is larger than 2 gigabytes**

If your Apricot PC is pre-installed with Windows 95, the entire hard disk is initially formatted as one partition.

If you have Windows NT, the first 2 Gbytes are formatted (using FAT) as a primary partition. The rest of the disk is untouched. You can repartition and reformat the disk using the Disk Administrator tool in the Administrative Tools (Common) folder.

If you have Windows for Workgroups, the first 2 Gbytes are formatted as the primary partition. The remainder of the disk is divided into formatted partitions of no more than 2 Gbytes and no less than 512 Mbytes.

## 3 DISKETTES and CDs

### Diskette drive

---

Your Apricot PC is fitted with a 1.44 Mbyte diskette drive. This accepts either 1.44 Mbyte (HD) or 720 Kbyte (DD) diskettes.

Each diskette has a rigid plastic cover, with a metal shutter that guards the disk surface. Never touch the exposed surface under the shutter – you could deform the disk or leave a fingerprint that might make the diskette difficult to read.

Keep diskettes away from dust, moisture, magnetic objects, and equipment that generates magnetic fields. Also, avoid extremes of temperature and exposure to direct sunlight. Otherwise, data recorded on the diskette may become corrupted.

#### Inserting a diskette

1. Insert the diskette with the metal shutter foremost, and with the label side facing upwards.

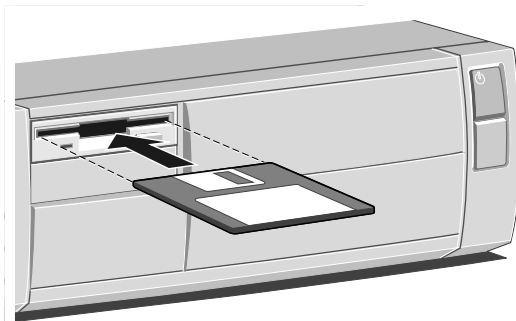

2. Push the diskette all the way in until it ‘clicks’ into place. The drive’s EJECT button pops out slightly. The drive flap stays open, leaving the diskette just visible.

#### Ejecting a diskette

- ◆ Wait until the drive’s activity indicator is unlit, then press the EJECT button.

## *Diskettes & CDs*

If a diskette becomes stuck in the drive, perhaps because its label has peeled back, do not attempt to remove it with tweezers or any similar implement; you risk damaging the drive. Call an authorised maintainer.

### **Write-protecting a diskette**

- ◆ A diskette can be write-protected by sliding a tab towards the edge of the diskette to expose the small hole beneath it (see illustration).

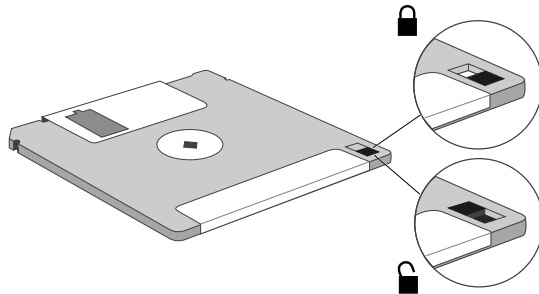

You can read, copy or print the files on a write-protected diskette, but you cannot create, rename or delete any files.

## CD-ROM drive (optional)

---

The CD-ROM drive can retrieve multimedia data from CD-ROM discs and multi-session Photo-CD discs. It can also play normal music CDs (the drive has its own headphone jack and associated volume control).

Keep CDs well away from dust and moisture, and avoid touching the surface of the CD. Avoid extremes of temperature and exposure to direct sunlight as these may cause the disk to warp.

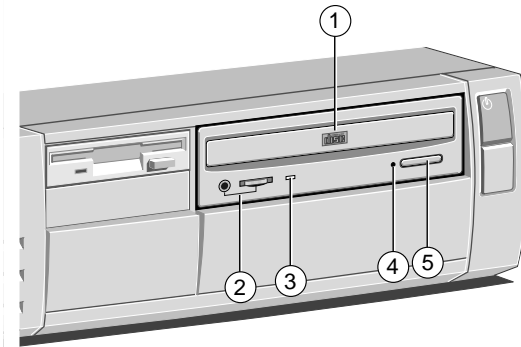

- 1 CD-ROM disc drawer (platter)
- 2 Headphone jack & volume control
- 3 Activity indicator (green = powered, amber = busy)
- 4 CD emergency eject hole
- 5 EJECT button (doesn't work while PC is turned off)

Do not attempt to move the computer while a CD is in the drive, especially if the CD is being played at the time.

---

### WARNING

*The laser beam inside the CD-ROM drive is harmful to the eyes if looked at directly. Do not attempt to disassemble the CD-ROM drive. If a fault occurs, call an authorised maintainer.*

---

### **Inserting a compact disc**

1. Press the EJECT button on the front of drive.
2. Place the CD centrally, printed side up, on the platter.
3. Push the EJECT button again, or gently push the front of the platter to draw it back into the drive.

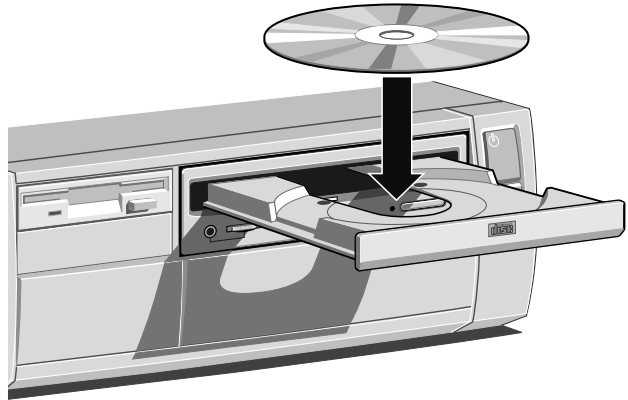

### **Ejecting a compact disc**

- ◆ Ensure that the drive's activity indicator is not showing 'busy', then press the EJECT button.

### **To eject the platter manually**

You may need to recover the CD, for example, during a power failure. You must first ensure that the computer is completely off (the indicator on the POWER button will be unlit). It is recommended to unplug the power cord for safety.

Insert a thin metal rod (such as an unwound paper clip) into the emergency eject hole as shown on the previous page. Push carefully and firmly.

# 4

## EXPANSION CARDS

Expansion cards (also known as expansion boards, controllers or adapters) are small self-contained circuit boards which extend the capabilities of the computer. For example, a graphics card could provide more specialised video functions than those offered by the on-board video system, or a modem card could provide a connection to the Internet via a telephone line.

Your computer can accept two basic types of expansion card:

- ◆ ISA or Industry Standard Architecture cards
- ◆ PCI or Peripheral Component Interconnect cards

You don't need to understand what these terms mean, but before adding a card to your computer you will need to know whether it is ISA or PCI and possibly its physical dimensions.

The following diagram shows the layout of the five expansion slots in your PC (as viewed from the rear). The sixth "slot" is reserved for the optional second serial port.

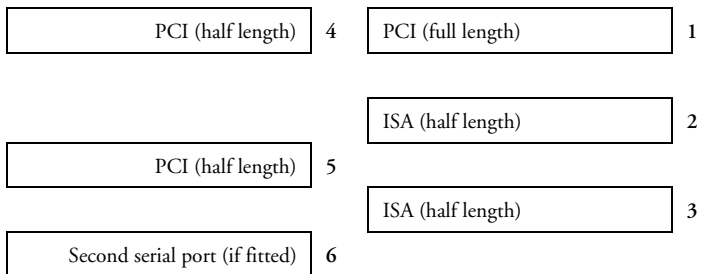

---

### IMPORTANT

*This system complies with the CE Marking Directive and its strict legal requirements. Use only parts tested and approved by Mitsubishi Electric PC Division. Failure to do so may result in invalidating both the compliance and your warranty. All expansion cards and drives must carry the CE mark to ensure continued compliance.*

---

### **Configuring the card**

---

Part of the installation procedure for an expansion card involves setting up or “configuring” the card so it will work correctly in the computer.

Most modern PCI cards employ a feature called “Plug and Play” (PnP). This allows Windows 95 – and other PnP-aware operating systems – to configure the card automatically the first time you turn on the computer after installing the card.

However, many ISA cards (and some PCI cards) require manual configuration. If manual configuration is required, you will probably need to specify at least two of the following:

- ◆ Interrupt request level (IRQ)
- ◆ Direct memory access (DMA) channel
- ◆ Base input/output (I/O) port address
- ◆ Base memory address

The important thing to understand is that the settings of the card you are installing must be different from the settings used by other cards already in the computer or by components on the computer’s motherboard. In other words, the settings must not “conflict”.

The documentation accompanying the card should tell you whether the card supports Plug and Play, or if not, how to configure it. Remember to check any diskettes supplied with the card for README or other help files.

Some cards require you to move jumpers or set switches on the card to configure them. This is best done before installing the card in the computer. Other cards can be configured by running a configuration program after installing the card. Some cards use a mixture of both methods.

Cards often come with pre-configured or default settings. It is best to rely on these settings as much as possible, and change them only if they conflict with other devices.



### **ISA Interrupt request level (IRQ)**

The “interrupt request level” or “IRQ” is the means by which the expansion card sends a signal to get the attention of, or interrupt, the processor. Your PC has interrupt levels numbered IRQ0 to IRQ15, many of which are needed for components on the computer’s motherboard. There are two ways round this.

- ◆ You can disable certain motherboard components either by means of the BIOS Setup utility or else by changing jumper settings on the motherboard. This frees the resources used by those components.
- ◆ The audio system, USB controller and standard input/output controller (e.g., for serial and parallel ports) are Plug and Play (PnP) devices. If you use BIOS Setup to exclude or reserve an interrupt that is usually assigned to one of these devices, an alternative interrupt will be assigned though Plug and Play and the original interrupt can instead be used by the expansion card.

See the *BIOS Setup & POST* chapter for more information about BIOS Setup. See the *Motherboard Features & Upgrades* chapter for more information about jumper settings and the usual assignment of interrupts to motherboard components.

### **Direct memory access (DMA) channel**

Some hardware devices can use a “DMA channel” to access system memory without directly burdening the processor. Your PC has DMA channels numbered DMA0 to DMA7. As with interrupts, you can use vacant channels or re-assign existing ones.

See the *Motherboard Features & Upgrades* chapter for more information about the usual assignment of DMA channels.

### **Base input/output (I/O) port address**

I/O ports are used by the processor to communicate with hardware devices. Each port appears to the processor as an address low down in its address space. Some expansion cards are also controlled by I/O ports. The “base I/O port address” specifies where the card’s ports begin.

### Base memory address

Some expansion cards are fitted with memory of their own, usually read-only memory (ROM) containing functional extensions to the computer's BIOS (basic input/output system) ROM. Some cards also have random-access memory (RAM).

In order that this memory can be recognised by the system processor, it must be mapped somewhere within the computer's own address space. By setting the "base memory address" you specify where the card's memory begins within the address space.

Typically, an expansion card's memory must be mapped onto the addresses between C8000h and DFFFFh – an area known as the upper memory block or UMB. You can exclude or reserve UMB regions with the BIOS Setup utility.

The card's documentation should list its possible base memory addresses. You will also need to know how much memory the card has, so that you can leave the right gap between this card's base address and the next.

### More about memory addresses

Memory *addresses* are always written in base 16 or "hexadecimal" notation. Unlike the ten digits of the decimal system (0-9), hexadecimal uses sixteen digits (0-9 and A-F, where A=10, B=11, C=12 and so on up to F=15).

Hexadecimal numbers are denoted either by the suffix "h" or by the prefix "0x". The final digit of a five-digit memory address is often omitted, so C8000h may be written as C800h.

Because *amounts* of memory are usually stated as kilobytes (Kbytes) rather than in hexadecimal notation, the following conversion table may be helpful:

4 Kbytes = 1000h	32 Kbytes = 8000h
8 Kbytes = 2000h	64 Kbytes = 10000h
16 Kbytes = 4000h	128 Kbytes = 20000h

## Installing the card

---

Read all these instructions through before attempting to install any expansion card.

---

### WARNING

*Never carry out any work inside the computer with AC power applied. Always shut down the computer and unplug all power cords before removing the top cover.*

---

The only tool required is a small cross-head screwdriver.

1. Turn off the computer and unplug all power cords.
2. Take suitable anti-static precautions and remove the system unit cover. For more information see “Anti-static precautions” in the *Safety & Regulatory Notices* at the start of this manual.
3. Decide in which of the available slots you wish to install the card, according to its type and size. In general it is easiest, where possible, to start with the lowest slot and work upwards.
- 4a. If the chosen slot is on the left-hand side of the system unit (when viewed from the front) remove its blanking plate by removing the securing screw. Keep the screw; it will be needed later to secure the card.
- 4b. If the chosen slot is on the right-hand side of the system unit (nearer the power supply) remove the plate with the security loop – labelled (A) in the illustration below – then remove the slot’s blanking plate.

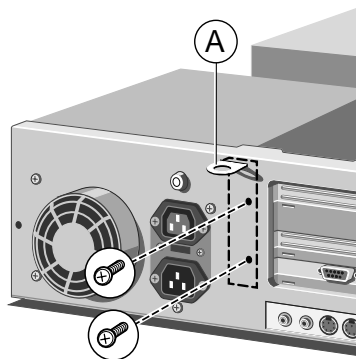

## Expansion Cards

5. If the card you are installing is configured by the means of jumpers or switches, check that it is correctly configured before proceeding.
6. When installing a card that uses the VESA/AMC video feature connector on the motherboard, it is best to plug the video feature cable into the motherboard before you install the card; otherwise, the card may get in the way of the connector. See the *Motherboard Features & Upgrades* chapter to locate the VESA/AMC connector.

---

### CAUTION

*Be careful how you use this connector. Some pins carry +5 V power which could damage the expansion card if it is incorrectly attached.*

---

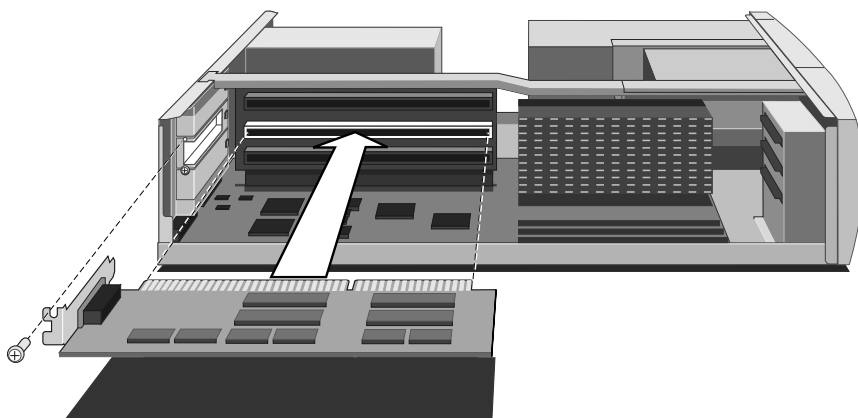

7. Position the expansion card alongside the slot in which you wish to install it. Align the rear of the card with the slot in the rear of the system unit, and, if the card is full length, align the front of the card with the card guide.
8. Slide the card into the slot ensuring that the card edge connector engages correctly with the socket on the riser board. Do not use excessive force.
9. Secure the card by replacing the screw or the security loop panel that you removed in Step 4.

10. Connect any necessary signal cables to the card.
11. Ensure no other cables or connectors have become dislodged, then replace the system unit cover.

### **Reserving ISA legacy resources**

---

If you have just installed an ISA card, your first task after turning on the computer is to run the BIOS Setup utility and reserve or exclude the legacy resources (that is, the interrupts and UMB regions) used by the card. This is necessary so that any Plug and Play components can be configured automatically and won't try to use the same settings. See the *BIOS Setup & POST* chapter for more information.

Alternatively, under Windows 95, you can use the Control Panel to change the resource settings used by devices:

1. Click the **Start** button in the taskbar, then **Settings**, then **Control Panel**.
2. Double-click on **System**, then click the Device Manager tab of the System Properties dialog.
3. Select the device whose resources you want to change, then click **Properties**.
4. Click the Resources tab of the device's Properties dialog, select the resource you want to change, then click **Change Setting**.

### **Telling Windows about the new hardware**

---

Windows 95 and Windows NT 4.x (or later) should automatically detect and configure cards that support "Plug and Play". In other cases you may have to tell Windows that you have installed new hardware, as follows:

1. Click the **Start** button in the taskbar, then **Settings**, then **Control Panel**.
2. Double-click on **Add New Hardware**.
3. Follow the instructions in the Add New Hardware Wizard.

## 5

# MOTHERBOARD FEATURES AND UPGRADES

This chapter describes the features of the Apricot motherboard designed for the 'Pentium®II processor' and gives step-by-step instructions for adding more system or video memory, upgrading the processor, and replacing the configuration battery. Details of all relevant motherboard connectors and jumper settings are included.

The *Welcome* chapter tells you how to remove the system unit cover. See the section on "Anti-static precautions" in the *Safety & Regulatory Notices* at the beginning of this manual for advice on how to avoid damaging your computer with static electricity.

---

### WARNING

*Never carry out any work inside the computer with AC power applied. Always shut down the computer and unplug all power cords before removing the top cover.*

---

---

### CAUTION

*Do not alter any jumpers or switch settings other than those identified in this chapter, unless told to by your Mitsubishi Electric PC supplier or an authorised maintainer. Otherwise, you may damage the system processor, the motherboard, or both.*

---

---

### NOTE

*After you have added more memory or upgraded the processor, the computer may not at first recognise the new configuration. Start the BIOS Setup utility, go to the Advanced menu and change the Reset Configuration Data item to "Yes", then restart the computer.*

---

# Motherboard features and upgrades

## Detailed view

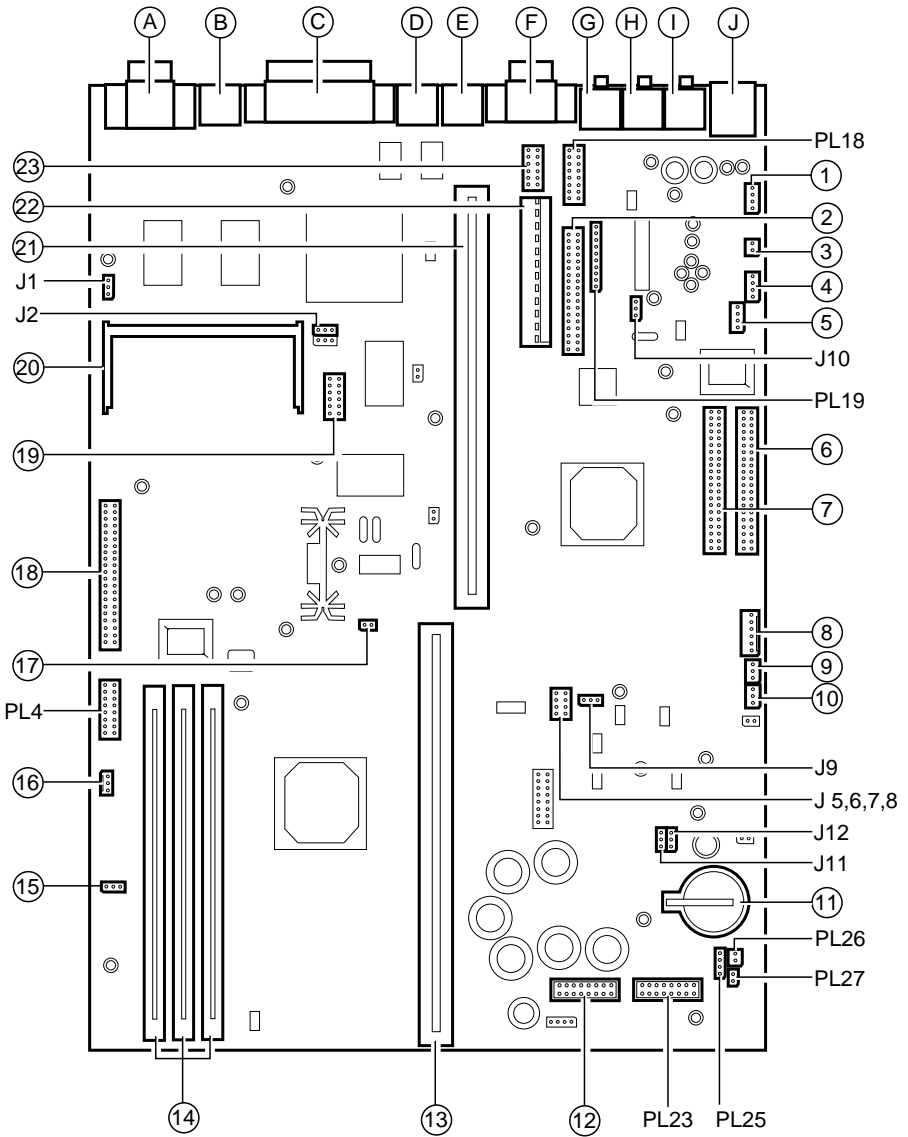











## Major board features

1 Aux. audio input (option)	9 'Wake on LAN' connect	17 Processor heat sense input
2 Floppy drive interface	10 'Wake on MODEM'	18 VEC/AMC connector
3 S/P Dif. (option) dig. audio	11 CMOS battery	19 TV tuner interface (option)
4 CD audio input	12 Front board conn. option	20 Video memory upgrade
5 Front panel USB (option)	13 Processor slot	21 Expansion card riser socket
6 Primary IDE interface	14 DIMM sockets	22 Main power socket
7 Secondary IDE interface	15 Case fan connector	23 COM2 interface. (option)
8 PSU control interface	16 CPU fan option	

## Jumpers and control connections

J1 On-board Video enable/disable	PL4 Server management (option)
J2 BIOS program enable/disable	PL18 MIDI/joystick interface (option)
J5-8 Processor clock multipliers	PL19 Voice MODEM connector
J9 DSP enable/disable (optional)	PL23 Front panel controls/options
J10 Audio subsystem enable/disable	PL25 Internal case speaker. If fitted
J11 Red power LED enable/disable	PL26 Message light (option)
J12 Clear CMOS	PL27 Message switch (option)

## External connections

Port	Purpose	Case Symbol	Port	Purpose	Case Symbol
A	VGA to monitor		F	Serial port COM1	
B	Video out (option)		G	Microphone jack	
C	Parallel to printer		H	Line out jack	
D	PS/2 Mouse port		I	Speaker jack	
E	PS/2 Keyboard port		J	Dual USB port	



## **LM78 System Monitor**

---

The motherboard has an on board monitoring system provided by an LM78 device.

The LM78 provides the system monitor functions as described below. An I<sup>2</sup>C link to an external (optional) management card allows access to the monitors even after a motherboard failure so long as the system 5V standby rail remains available, i.e the AC power cord is still connected even when the system is in “Off” mode.

The following functions are provided by the LM78:

- ◆ Monitoring of system fans
- ◆ Monitoring of system voltages; +12V, +5V, +3.3V, processor, +1.5V, -5V and -12V rails
- ◆ Monitoring of system temperature (i.e the motherboard surface temperature)
- ◆ Monitoring of chassis intrusion (cover removal)

With the installation of a server management card these functions can be accessed and checked via a suitably set up workstation on the network by an authorised user or supervisor.

The system’s operation and integrity can be monitored even with the system in “Off” mode. The system can also be remotely reset.

### On-board video disabling (J1)

If you install a video adapter expansion card, the computer should automatically detect this and disable the on-board video adapter. If for some reason this does not happen, and you experience problems with a newly-fitted card, you can manually disable the on-board video adapter by moving jumper J1 from position 2-3 (EN) to position 1-2 (DIS).

### Processor multiplier (J5 to J8) CPU bus 66MHz

The details below are given for the clock speeds of processors known at the time of writing. Higher speed and overdrive processors may become available, in which case consult your supplier for further information.

J5	J6	J7	J8	Ratio	CPU speed
I	I	I	O	3	200
O	I	I	O	3.5	233
I	I	O	I	4	266
O	I	O	I	4.5	300

I=jumper fitted                      O=No jumper

### Audio DSP (J9) (option)

If you need to disable the PCI audio accelerator (DSP) move jumper J9 from pins 1-2 (EN) to pins 2-3 (DIS).

### Audio disabling (J10)

The on-board audio system can be disabled by removing jumper J10 from pins 1-2 (EN) to pins 2-3 (DIS). Disabling the audio system frees the interrupt and DMA channel used by that system (normally IRQ5 and DMA1).

### Power Mode light colour (J11)

Normally, the Power Mode light is *[red]* when the system is in Off mode. If you move jumper J11 to pins 2-3 (OFF) the *[red]* light is extinguished in Off mode. All other modes remain active.

However it provides a useful warning to indicate that the power cord is still connected and should be left in the 1-2 (ON) position.

## BIOS upgrade and reprogram (J12, J2)

These jumpers should not normally be changed except by a service engineer or at the direction of a service engineer.

CMOS is cleared by moving the jumper J12 to the 2-3 (CLR) position for a few moments while the system is turned off and the power cord removed, then returning it to the 1-2 (NOR) position. It **must** be returned to normal before the power is reconnected.

BIOS reprogramming (J2) requires special software.

You must ensure that BIOS reprogramming is enabled if you want to use the optional Apricot LS Security Card (LOC Technology).

<b>Clearing CMOS</b>	<b>J12</b>
CMOS battery connected (default)	1-2*
CMOS battery disconnected	2-3
<b>BIOS reprogramming</b>	<b>J2</b>
Enabled	1-2
Disabled	2-3

\* This jumper **must** be returned to the normal position before reconnecting the power cord.

## Fan Connectors, PL3 & PL2

<b>Pins</b>	<b>CPU Fansink PL3</b>	<b>Pins</b>	<b>Main fan PL2</b>
1	Ground	1	Ground
2	+ 12v	2	+ 12v (controlled)*
3	Fan Fail	3	Fan Fail

\* This voltage varies to control the fan speed. This is determined from the processor's heatsink temperature sensor.

## Motherboard IRQs

Components	Interrupts (IRQs)															
	0	1	2	3	4	5	6	7	8	9	10	11	12	13	14	15
System timer	■															
Keyboard controller		■														
PIC daisy chain			■													
Serial port 2				BS	■	■	■	■	■	■	■	■	■	■	■	■
Serial port 1				■	BS	■	■	■	■	■	■	■	■	■	■	■
Audio						J	■	■	■	■	■	■	■	■	■	■
Diskette controller							BS	■	■	■	■	■	■	■	■	■
Parallel port (usually sharable)				■	■	■	■	■	BS	■	■	■	■	■	■	■
Real time clock									■	■	■	■	■	■	■	■
On-board video										J	■	■	■	■	■	■
USB				■	■	■	■	■	■	■	BS	■	■	■	■	■
Mouse													BS	■	■	■
Co-processor														■	■	■
Primary E-IDE															■	■
Secondary E-IDE																BS

■ Fixed assignment    □ Usual assignment    ■ PnP alternative  
 BS = Can be disabled by BIOS Setup    J = Can be disabled by moving a jumper

## Motherboard DMA channels

Components	DMA channels							
	0	1	2	3	4	5	6	7
Audio	■	J	■	■	■	■	■	■
Diskette controller			BS	■	■	■	■	■
Parallel port (in ECP mode)			■	■	BS	■	■	■
DMAC daisy chain					■	■	■	■

■ Fixed assignment    □ Usual assignment    ■ PnP alternative  
 BS = Can be disabled by BIOS Setup    J = Can be disabled by moving a jumper

## **Replacing the configuration battery**

---

The computer keeps a record of its current hardware configuration in a CMOS memory chip which is sustained by a small battery. This battery has a life of up to 5 years. If you find that you have to reconfigure the computer every time you turn it on, the battery is probably failing and needs to be replaced.

The battery is a 3 volt lithium type (CR2032 or equivalent) typically used in calculators, watches and other small, battery-powered electronic items.

Read carefully the following instructions before commencing work.

1. Turn off the computer and unplug all power cords. See the section on “Anti-static precautions” in the *Safety & Regulatory Notices* at the beginning of this manual for advice on how to avoid damaging your computer with static electricity.
2. Carefully disconnect and remove the floppy drive assembly. Take note of all cable positions before removal.

---

### **WARNING**

*Do not use a metal or other conductive implement to remove the battery. If a short-circuit is accidentally made between its positive and negative terminals, it may cause the battery to explode.*

---

3. Using a **non-conductive** implement, release the latch that holds the battery in place. The battery will pop up allowing you to lift it out of the holder.
4. Taking care not to touch the top or bottom surface of the new battery, pick up the replacement with the positive (+) terminal upwards and press the battery into the holder using a non-conductive implement.
5. Replace the floppy assembly you had to remove and replace the system unit cover.
6. Dispose of the old battery in accordance with the battery manufacturer’s instructions.

When you next turn on the computer you will have to run the BIOS Setup utility to enter the hardware configuration.

## Upgrading the motherboard

---

### CAUTION

*Care must be taken in the purchase of upgrade parts to ensure both compatibility with the system and the compliance with appropriate approvals and certification, e.g. CE marking within Europe. Using non-approved parts may invalidate your warranty and system approvals.*

---

The only tool required to complete the installation of the upgrades is a small cross-head screwdriver.

The tasks are not difficult, but if you do not feel confident about the work involved, you may wish to have your supplier or service organisation complete it for you.

### WARNING

*Never carry out any work inside the computer with AC power applied. Turn off the computer and unplug all power cords before starting work.*

---

## Adding more memory

The motherboard has three DIMM (Dual Inline Memory Module) sockets, each of which accept DIMMs of up to 128 Mbytes, in any combination. The slot nearest to the processor is recommended to be used first.

### DIMM SPECIFICATION

*The DIMMs you use must meet the following specification:*

*Serial Presence Detect (SPD), gold contact, 64-bit, (or 72-bit ECC), unbuffered, 3.3V, SDRAM-type with a CAS latency of 2 at 66 MHz.*

*The ECC capabilities of 72-bit DIMMs will only operate if all the DIMMs in the system are 72-bit.*

*Using DIMMs of a different type could affect system performance with a risk of damaging the motherboard.*

---

### **Fitting and removing DIMMs**

Read all of these instructions through carefully before you start work.

Turn off the computer and unplug all power cords. Take suitable anti-static precautions and remove the system cover. See the section on “Anti-static precautions” in the *Safety & Regulatory Notices* at the beginning of this manual for advice on how to avoid damaging your computer with static electricity.

Leave the DIMM in the antistatic packaging until the last possible moment and when you do take the DIMM out of its packaging, hold it by its ends and avoid touching the metal contacts.

Follow the diagrams and simple instructions on the following pages to insert each DIMM. It will vary slightly depending on what type of sockets are fitted on the motherboard.

### **Afterwards**

After you have added more memory, the computer may not at first recognise the new configuration. Start the BIOS Setup utility, go to the Advanced menu and change the Reset Configuration Data item to “Yes”, then restart the computer.

However, after fitting any memory upgrade, an error message should occur, check that you have:

- ◆ Correctly fitted the DIMMs in their slots.
- ◆ Installed DIMMs of the correct type.

It may be necessary to refit the original memory to check if there is a problem with your new modules.

## Fitting a DIMM

---

Do not use excessive force. If the module will not fit easily, remove it and start again.

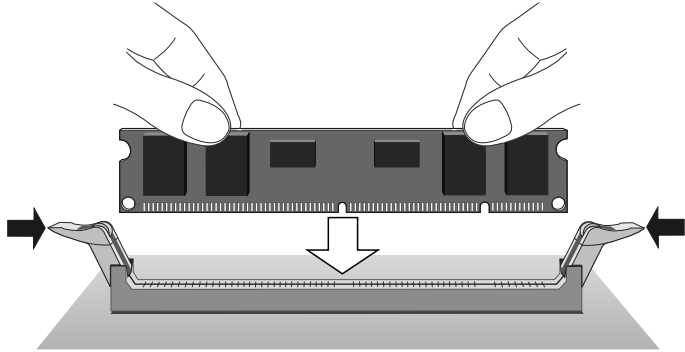

*If you have this type of socket, the DIMM is inserted vertically and held in place by the clips at each end.*

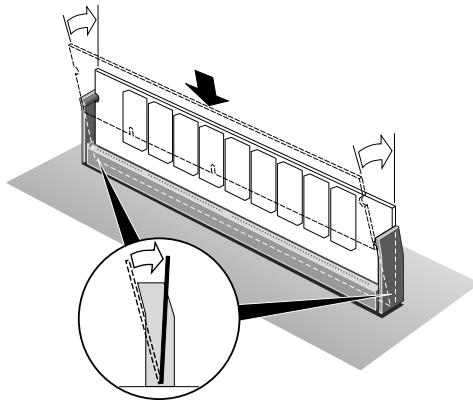

*If you have this type of socket, the DIMM is inserted at a slight angle then lent back in the socket until it clips into place.*



## Removing a DIMM

---

Do not use excessive force. If the module will not come free easily, check that the holding clips are clear of the module ends.

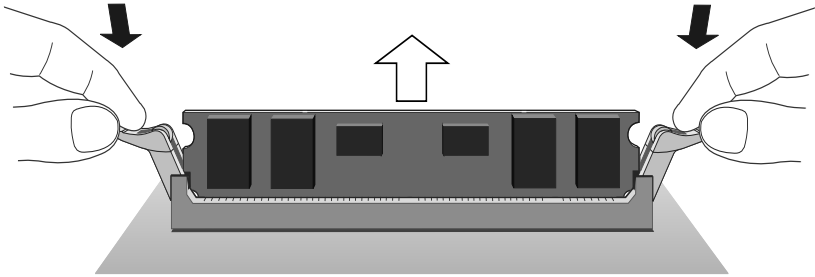

*If you have this type of socket, press the tabs on both of the socket's end clips at the same time. This releases the DIMM and lifts it partly out of the socket.*

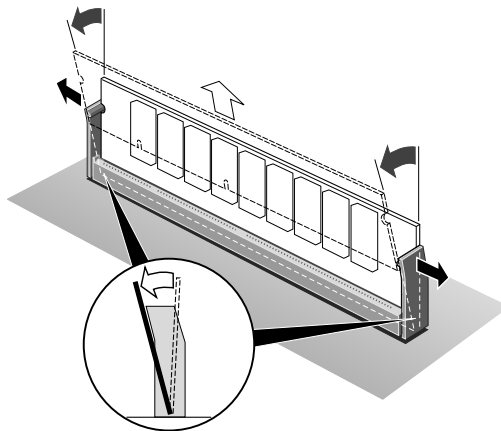

*If you have this type of socket, carefully ease apart the clips at each end to free the DIMM. The DIMM can then be tilted forward and lifted out of the socket.*

## Adding more video memory

---

Video memory is memory reserved for use by the on-board video controller. More video memory can provide more colours or higher resolutions to an extent determined by the capabilities of your monitor.

Check the amount of video memory fitted in your computer. You must fit a module of equal value. For example, if your computer has 2Mb of video memory, you must fit a 2Mb SoDIMM (Small outline Dual Inline Memory Module).

1. Turn off the computer and unplug all power cords.
2. Take suitable anti-static precautions and remove the system unit cover. For more information see the “Anti-static precautions” section in the *Safety & Regulatory Notices* at the start of this manual.

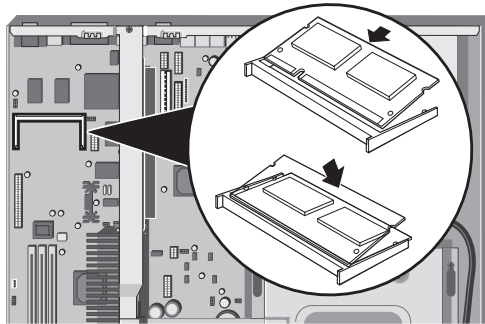

3. Remove any expansion cards that impede access to the video memory upgrade socket (see the motherboard diagram at the start of this chapter).
4. Unpack the upgrade kit. Hold the SoDIMM chip by its edges and be careful not to touch the metal pins.
5. Insert the SoDIMM into the socket as shown in the illustration.
6. Replace any expansion cards you removed earlier and refit the system unit cover.

You can now reconfigure your operating system to use the expanded capabilities of the video controller.

## The processor assembly

---

### To remove the existing processor

1. Turn off the computer and unplug all power cords. Take suitable anti-static precautions and remove the system cover. See the section on “Anti-static precautions” in the *Safety & Regulatory Notices*.
  - ◇ If the system was in use just before starting this procedure, the processor **will be hot**, wait at least 15 minutes.
2. If there are any expansion cards fitted that obstruct access to the processor, you may have to remove them.
3. Remove the floppy drive assembly.
4. Remove the metal support bar across the centre of the chassis.
  - ◇ Be careful, this also supports and is fixed to, the expansion riser card.

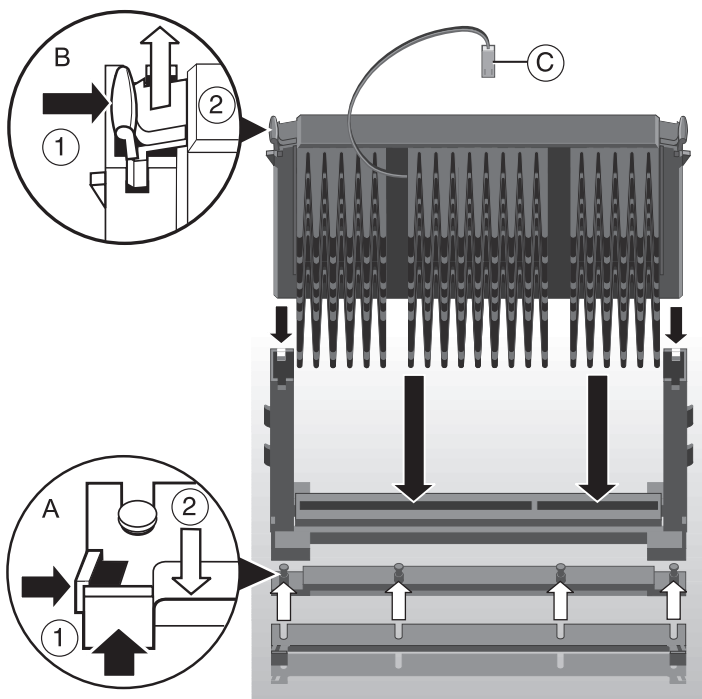

## Motherboard features and upgrades

5. Disconnect the heat sensor connector (marked 'C' on the illustration) that goes to PL9 on the motherboard.
6. See 'A' in the illustration. Carefully squeeze together the grips at both ends (1) of the heatsink support bracket (2) and slide it away.
  - ◇ Some designs of heatsink do not have this bracket fitted.
7. See 'B' in the illustration. Press in the clips (1) at both ends of the top of the processor body to depress the retaining pins out of the vertical supports. Then lift the processor body (2) out of the socket.

---

### CAUTION

*Handle the processor with care, by the body only. Avoid touching the connector at the bottom. Store in an antistatic container.*

---

### To fit a new processor

It should be noted that any upgrade or overdrive processor will not have the heat sensor as fitted to the original processor. This will cause the front case fan to operate at full speed continuously, with an increase in noise levels.

1. Take the processor out of its anti-static packaging. Hold the processor by its edges, or its heatsink and *avoid touching the edge connector*.
  - ◇ The upgrade processor and the socket are keyed to ensure that the processor is installed in the correct orientation. It will only fit into the socket one way.
2. Slide the processor into the vertical guides and down into the socket, making sure that it is correctly aligned and that you do not bend or otherwise damage the supports. **Do not use excessive force.**
3. Apply just enough pressure to overcome the resistance offered by the socket. Ensure that the retaining pins snap into the sockets on the end supports.

## *Motherboard features and upgrades*

4. Refit the heatsink support, making sure that it is correctly and fully seated on the pins. It should snap into place.
  - ◇ This bracket may not be fitted with some heatsink designs, or may not be needed with the the new processor.
5. Refit the chassis metal strut to its original position, making sure you correctly tighten the screws.
  - ◇ Check also the screws securing the expansion riser card are refitted and tightened.
6. The upgrade or overdrive processor may have its own cooling fan built into the heatsink. This will have a power lead that will need to be connected to PL3 on the motherboard, (marked '16' on the motherboard diagram).
  - ◇ If the fan has only a two pin connection, ensure it is connected to pins 1 and 2 of PL3.
7. Now adjust the processor multiplier speed links on the motherboard, (Jumpers 5 to 8) in conjunction with the new processor's data sheet.

---

### **WARNING**

*This processor requires continuous airflow.*

*Ensure that the supply lead for the front casing fan is still connected to PL2 to ensure adequate airflow over the processor assembly.*

---

8. Return the floppy drive assembly to its original position.
9. Return to their original position any expansion cards that had been removed earlier, then refit and secure the system cover.

## 6 HARD DISK UPGRADES

This chapter describes how to add a second hard disk to your computer.

---

### WARNING

*Never carry out any work inside the computer with AC power applied. Always shut down the computer and unplug all power cords before removing the top cover.*

---

### Configuring the drive

---

Your computer can accommodate two E-IDE hard disk drives, known as the master and slave drives. The first drive, which contains the operating system, is always configured as the master. The second drive must be configured as the slave.

Hard disk drives are normally configured as master or slave by using jumpers on the drive itself. Configuration details vary from drive to drive. Most drives are supplied with documentation describing how to configure the drive. If you are uncertain about configuring the drive consult your supplier.

---

### EXAMPLE

*The example drive shown below is configured as master or slave by the position of a jumper on the rear of the drive.*

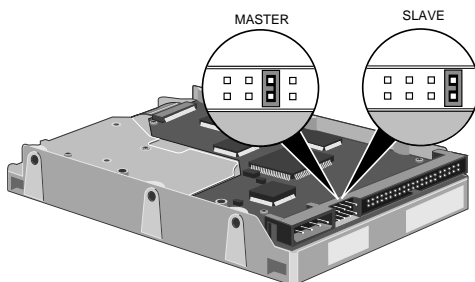

### Installing the drive

---

To install a second hard disk drive:

1. Turn off the computer and unplug all power cords.
2. If there is a diskette in the diskette drive, remove it.
3. Take suitable anti-static precautions and remove the system unit cover. For more information see “Anti-static precautions” in the *Safety & Regulatory Notices* at the start of this manual.
4. Disconnect the power and signal (ribbon) cables from the rear of the diskette drive. Take careful note of how they are fitted. Loosen the two screws labelled (A) in the diagram below. Slide the diskette drive assembly towards the rear of the system and lift it out.

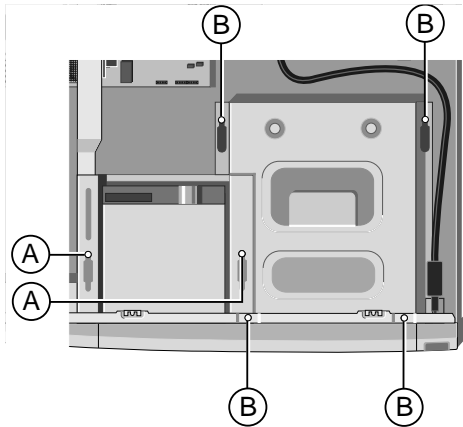

5. Disconnect the power, signal and CD audio cables from the rear of the CD-ROM drive. Take careful note of how and where they are fitted. Loosen the four screws labelled (B) in the diagram above. Slide the CD-ROM assembly rearwards and lift it out of the system unit. You now have access to the hard disk drive (HDD) assembly.
6. Disconnect the power and signal cables from the rear of the existing (master) hard disk drive. Loosen the four screws labelled (C) in the diagram below. Lift the HDD assembly out of the system unit and place it on an anti-static surface.

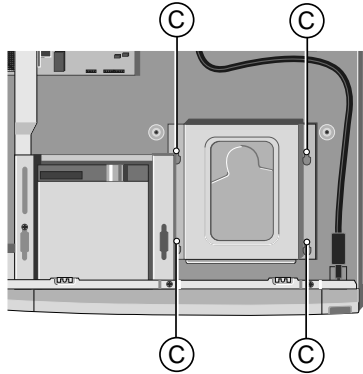

7. Fit the new (slave) hard drive into the HDD assembly using the special screws provided. Try not to touch either drive's electronics.

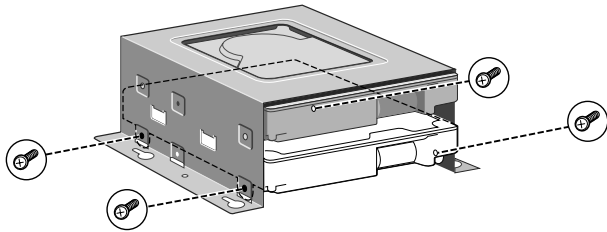

8. Put the HDD assembly back into the system unit and tighten the (C) screws to secure it to the chassis. Re-attach the HDD signal cable to the master and slave drives. (Note that the HDD signal cable has two connectors on it; one for the master drive and one for the slave drive.) Attach a spare power cable to the slave drive, and another to the master drive. (It does not matter greatly which of the available power cables you choose.)
9. Put the CD-ROM assembly back into the system unit and tighten the (B) screws to secure it to the chassis. Re-attach the CD-ROM power, signal and CD audio cables.
10. Put the diskette drive assembly back into the system unit and tighten the (A) screws to secure it. Re-attach the diskette drive power and signal cables.
11. Check to ensure that no other cables or connections have become dislodged or trapped during the work, then replace the system unit cover.



### **Partitioning and formatting the drive**

---

The first time you turn on the computer after fitting the new drive, the power-on self-test (POST) detects the change in configuration and starts the BIOS Setup utility automatically. If the drive is larger than 8 gigabytes, you will have to enable the **LBA Mode Control** option for that drive. Otherwise, all you have to do is save the new configuration and exit.

The new drive will initially be blank. Before you can use the drive, you must partition and format it.

#### **Windows 95**

Use the MS-DOS **Fdisk** program to create partitions on the disk. The **Fdisk** program can be run in an MS-DOS window within Windows. Type **Help Fdisk** at the MS-DOS command prompt to find out more. After using **Fdisk**, you are prompted to restart the computer. Once back in Windows, you can format the partitions by opening the My Computer folder, selecting the new Drive icon and choosing the **Format** command from the File menu.

---

#### **CAUTION**

*When you run **Fdisk**, it assumes that you want to work with the first, or master, drive (it says the **Current fixed disk drive is 1**). To switch attention to the slave drive, choose **Select next fixed disk drive** (option 5) from the main menu.*

---

#### **Windows NT**

Use the Disk Administrator tool in the Administrative Tools (Common) folder. This both creates partitions and formats them.

#### **Windows for Workgroups**

Use the MS-DOS **Fdisk** program to partition the disk followed by the MS-DOS **Format** command to format the partitions. Use the MS-DOS **Help** command to find out more about **Fdisk** and **Format**. See your MS-DOS documentation for instructions on using MS-DOS Help. A limitation of Windows for Workgroups is that each partition can be no more than 2 gigabytes in size.

# 7

## BIOS SETUP & POST

BIOS (pronounced “bye-oss”) stands for ‘basic input/output system’. The BIOS mediates between the computer’s hardware – the processor, memory, and so on – and its software – the operating system and your programs. The BIOS program is kept in permanent, read-only memory or ROM (although if necessary it can be upgraded by an authorised maintainer).

BIOS Setup is a helpful utility that forms part of the BIOS program. It allows you to view and alter the computer’s hardware configuration. It is also used to configure various security and power-saving options. Configuring the computer is necessary to ensure that the software you use can recognise and exploit the hardware’s capabilities.

The current configuration is kept in a special area of memory, called CMOS memory, and maintained by a battery so that the configuration is preserved even while the computer is switched off.

Your computer arrives already configured, but may need to be configured again after you add or remove add-on options such as memory modules or expansion cards.

Whenever the computer is turned on, the BIOS power-on self-test (POST) routine tests various hardware components, including memory, and compares the actual configuration of the computer with that recorded in permanent (CMOS) memory.

A configuration discrepancy could arise if you have just installed or removed a hardware option (for example, if you have added or replaced memory). In this case you may be diverted directly into the BIOS Setup utility.

### BIOS Setup

---

To start the BIOS Setup utility:

1. Turn on or restart your computer.
2. Wait until the Mitsubishi Electric logo appears on the screen.



3. Press the F2 key.
4. If you have previously defined a Supervisor password, you are prompted for it before BIOS Setup starts.

### If BIOS Setup starts on its own

BIOS Setup might start on its own for three reasons:

- ◆ The power-on self-test (POST) detects a configuration error or fault. This may be signalled by one or more POST error messages. If a persistent fault is indicated, make a note of any error messages and the current configuration settings before calling an authorised maintainer.
- ◆ The CMOS battery may be running down. This may cause spurious POST error messages. If this happens every time you turn on the computer, you may have to change the battery.
- ◆ The computer's configuration may have changed, for example by the addition of more system memory or an expansion card. In this case you may have to define the new configuration.

### Control keys

Use the keys listed in the legend bar at the bottom of the BIOS Setup screen to make your selections or exit the current menu.

Sub-menus are marked by a ► pointer. To display a sub-menu, use the arrow keys to move the cursor to the sub-menu you want, then press ENTER.

Changeable fields are enclosed in square brackets. To select an item, use the arrow keys to move the cursor to the field you want. Then use the PLUS (+) and MINUS (-) keys to select a value for that field.

<b>Press</b>	<b>To</b>
F1 or ALT-H	View a general help topic. Press ESC to close the help window.
ESC	Exit the current menu.
LEFT or RIGHT arrow	Select a different menu.
UP or DOWN arrow	Select fields on the current menu.
PLUS (+) or F6 or SPACEBAR	Select the next value for the current field.
MINUS (-) or F5	Select the previous value for the current field.
ENTER	Make a selection from the menu bar or enter a sub-menu.
HOME or END	Move the cursor to the top or bottom of the current menu.
PAGE UP or PAGE DOWN	Move the cursor to the next or previous page of the current menu.
F9	Restore the default settings for the fields on the current menu.
F10	Save the changes you've made and exit from BIOS Setup.

---

### CAUTION

*The default BIOS settings may not be appropriate for your particular system. Make a note of the current settings before pressing F9 or using the Load Setup Defaults option of the Exit menu.*

---

### Getting help in BIOS Setup

You can at any time get general help about the control keys by pressing the F1 key.

The help window on the right-hand side of each menu displays help text for the currently-selected field. It changes as you move the cursor from one field to another.

## Reserving ISA legacy resources

To reserve interrupts and upper memory block (UMB) regions for ISA expansion cards, go to the **Advanced** menu, select **PCI Configuration**, then select **PCI/PNP ISA IRQ Resource Exclusion** or **PCI/PNP ISA UMB Region Exclusion** as required.

## Multi-boot facility

---

Immediately after the first screen, where you are asked to enter your fingerprinting password, a second screen displays various POST messages such as the memory test. While this screen is on display, a message at the bottom says:

**Press <F2> to enter setup or <ESC> to enter Boot Menu**

If you press the <ESC> key this menu will appear:

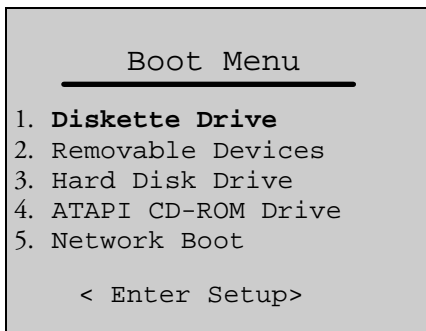

This menu can be used to temporarily use another drive or device to boot your system, for example a bootable CD-ROM, without having to enter the BIOS setup. Simply use the up and down arrows to make a selection. This change will not be permanent and the system boot will revert to the normal BIOS setting the next time you switch on your system.

## Power-on self-test

---

### Recoverable POST errors

Whenever a recoverable (non-terminal) error occurs during POST, the BIOS displays an error message describing the problem (the most usual are described below). After some messages, you may be prompted to **Press <F1> to resume, <F2> to enter Setup** or just **Press <F2> to enter Setup**.

In general, you should respond to these errors as follows:

- ◆ Shut down the computer, wait 20 to 30 seconds, and then turn it on again to see if the problem is still reported.
- ◆ Check that all external cables are securely connected.
- ◆ Try running the BIOS Setup utility to reconfigure the system. If the computer won't start after you make changes in BIOS Setup, try restoring the original values.
- ◆ Open up the system unit and check that all internal signal and power cables are securely connected.
- ◆ If the problem persists, contact your supplier or authorised maintainer.

#### Diskette drive A error

Drive A: is present but fails the POST diskette tests. Check that the drive is defined correctly in BIOS Setup. If necessary, open the system unit and check that the drive's signal (ribbon) cable is connected.

#### System/Extended/Shadow RAM failed at offset: *xxxx*

##### Failing bits: *yyyy*

System, extended or shadow memory is not working, or not configured properly, at offset *xxxx*. The hexadecimal number *yyyy* is a map of the bits at the address which failed the memory test. Each "1" in the map represents a failed bit.

#### Fixed disk *X* failure or Fixed disk controller failure

A fixed (hard) disk drive is not working or not configured properly. Check that the drive is defined correctly in BIOS Setup. If necessary, open the system unit and check that the drive's signal (ribbon) cable is connected.

### **Incorrect drive A type - run SETUP**

The diskette drive is not correctly specified in BIOS Setup.

### **Invalid NVRAM media type**

Problem with NVRAM (non-volatile random-access memory).

### **Keyboard error [nn] or Keyboard controller error**

There is a problem with the keyboard or (less likely) the standard I/O controller on the motherboard. If POST discovers a stuck key it displays its scan code.

### **Operating system not found**

An operating system cannot be located either on a system diskette or on a hard disk. Start BIOS Setup and check that the diskette and/or hard disk drives are specified correctly.

### **Parity check 1 xxxx or Parity check 2 xxxx**

Parity error found on the system (1) or I/O (2) bus. The BIOS attempts to locate and display the address xxxx. If it cannot locate the address, it displays “????”.

### **Previous boot incomplete - default configuration used**

The previous POST did not complete successfully. POST loads default values and offers to start BIOS Setup. If the failure was caused by incorrect values and they are not corrected, the next boot will likely fail too.

### **Real-time clock error**

Enter BIOS setup and check the System Time and System Date settings on the Main menu.

### **System battery is dead - replace and run Setup**

Replace the configuration battery as instructed in the *Motherboard Features & Upgrades* chapter, then use BIOS Setup to reconfigure the system.

### **System cache error - cache disabled**

The RAM cache failed POST and BIOS disabled it.

### **System CMOS checksum bad - run Setup**

System CMOS has been corrupted or modified incorrectly, perhaps by an application program that changes data stored in CMOS. Run BIOS Setup and reconfigure the system either by getting the default values or by making your own selections.

## **Terminal POST errors and beep codes**

---

There are several POST routines that shut down the computer if they fail. If possible, the BIOS displays a two-digit hexadecimal code and/or sounds a sequence of beeps to identify the point at which POST failed. The most usual errors are listed below.

The BIOS also issues one long tone followed by two short tones if the video system is faulty or if an external ROM module (including video ROM) fails.

Turn off the computer for 30 seconds and then try again. If the fault persists, make a note of the error code (if any) and call your supplier or authorised maintainer.

<b>Code</b>	<b>Beeps</b>	<b>Test which failed</b>
16	1-2-2-3	BIOS ROM checksum
20	1-3-1-1	DRAM refresh.
22	1-3-1-3	8742 keyboard controller
2C <i>xxxx</i>	1-3-4-1	RAM failure on address line <i>xxxx</i> .
2E <i>xxxx</i>	1-3-4-3	RAM failure on data bits <i>xxxx</i> of low byte of memory bus.
30 <i>xxxx</i>	1-4-1-1	RAM failure on data bits <i>xxxx</i> of high byte of memory bus.
46	2-1-2-3	Check ROM copyright notice
58	2-2-3-1	Test for unexpected interrupts
98	1-2	Video configuration failure, or option ROM checksum failure. (One long, two short beeps.)



# 8 TROUBLESHOOTING

This chapter offers advice if you suspect a fault with your computer. It is concerned mainly with problems caused by the computer itself; problems more often arise from other sources such as your operating system or application software.

It must also be remembered that it can be very easy to leave off or dislodge cables inside the computer when fitting expansion cards, or upgrading the motherboard, or indeed anything that requires temporary removal of the system cover.

---

## IF YOU ARE APPREHENSIVE

*Make a note of any of the symptoms, error codes, displayed messages and so on, then turn off the computer and unplug all power cords before consulting your supplier or maintenance provider.*

---

## Problems when starting

---

### If you suspect a blown fuse

In the United Kingdom, and some other countries, AC plugs contain fuses. If the fuse in the system's unit AC plug blows when you turn on the computer, this may be caused by an AC power surge, but is more often a symptom of problems with the computer or its peripherals. Follow these steps:

1. Turn off the computer and unplug all power cords.
2. Unplug all peripherals.
3. Try to discover the cause of the fault. If none is apparent, replace the blown fuse with one of the same rating, reconnect the system unit power cord and try to turn it on again.
4. If the replacement fuse blows, call your supplier or maintenance provider.

If the replacement fuse does not blow, reconnect a peripheral and turn it on. Repeat this step for each peripheral in turn.

### **Power-on self-test (POST)**

Whenever the computer is turned on, the BIOS POST routine tests various hardware components, including memory, and compares the actual configuration of the computer with that recorded in CMOS memory.

If POST detects a hardware fault, one or more POST error codes or messages may be displayed. See the *BIOS Setup & POST* chapter for more information and advice.

### **Failure to boot**

On completion of POST, the computer attempts to boot from a system diskette or bootable hard disk partition. The table below lists some of the messages that might appear during the boot sequence.

#### **Non-system disk or disk error**

The diskette drive contains a non-system diskette. Replace it with a system diskette and press F1.

#### **Diskette read failure**

The diskette is either not formatted or defective. Replace it with a system diskette and press F1.

#### **No boot sector on fixed disk**

The hard disk has no active, bootable partition or is not formatted. If you are still using the original master hard disk drive supplied with your computer, this is a serious problem requiring the attention of a service engineer. If you have just replaced the master drive with an unformatted one, you must insert a system diskette, press F1, and format the new hard disk as described in your operating system manuals.

#### **Fixed disk read failure**

The hard disk may be defective. Press F1 to retry. Make sure the drive is correctly specified in the BIOS setup utility. If the problem persists, insert a system diskette, press F1, backup the data held on the defective hard disk and try reformatting it.

#### **No boot device available**

This may indicate a fault in the diskette or hard disk drive, or perhaps a damaged system diskette. Press F1 to retry, using

another system diskette, if possible. Make sure that a boot device is correctly specified with the BIOS Setup utility. If the problem persists contact your supplier or authorised maintainer.

### **Common problems**

---

If you encounter a problem with the computer the following sections suggest checks to make before you alert your supplier, authorised maintainer or support organisation. The checks listed cover the causes of common problems.

#### **Connections**

Check that all power and signal cables are securely connected to the correct port on the computer.

The keyboard and mouse are particularly easy to connect into the wrong port. Although the connectors are identical, the keyboard will not work if plugged into the mouse port, and vice versa.

#### **Power**

Check that the AC power supply is switched on, and that the fuse in the AC plug (if any) has not blown. If the system still does not seem to be getting power, obtain another power cord from your supplier.

#### **Monitor**

If there is no display check that the monitor is turned on, and the brightness and contrast controls are not too low.

If you have fitted a new video controller expansion card and subsequently encounter problems try disabling the on-board video controller by removing a jumper from the motherboard. See the *Motherboard Features & Upgrades* chapter for more information.

#### **Mouse**

If the screen cursor moves jerkily, the ball inside the mouse may require cleaning. Open the base of the mouse can clean the ball in water mixed with a small amount of mild detergent. Clean any

## Troubleshooting

grease and dust from the rollers inside the mouse with a cotton swab moistened with a solvent cleaner.

### **Keyboard**

If the keyboard response is poor, something may be trapped under the keys. Turn the keyboard upside down and shake it; do not probe between the keys as this may cause further damage.

If you spill something on the keyboard and it stops working:

- ◆ If the liquid is viscous, unplug the keyboard and call your supplier or an authorised maintainer.
- ◆ If the liquid is thin and clear, try unplugging the keyboard, turning it upside down to let the liquid drain out, and drying it for at least 24 hours at room temperature. If the keyboard still won't work, call your supplier or an authorised maintainer.

### **Expansion cards**

If an expansion card does not work, check that all internal cables are securely connected, that the card is configured correctly, that its use of system resources does not conflict another card or motherboard component, and that legacy resources (if it is an ISA card) are properly declared in the BIOS Setup utility. Check also that the software which drives or uses the card is correctly configured.

### **System BIOS**

Use the BIOS Setup utility to ensure that the settings are correct. If the settings appear to have altered, there may be a fault with the CMOS battery which may need to be replaced (see the *Motherboard Features & Upgrades* chapter for instructions).

### **Diskette drive**

If you have problems accessing a diskette, check that it is inserted correctly, that it has been correctly formatted, that it is not write-protected, and that the diskette drive controller is enabled. Some application software also may not allow you to read or write to diskettes during certain other operations, or until you are about to exit the program.

**CD-ROM drive**

If you have problems accessing a CD, check that you have allowed a few seconds for the disk to spin up to full speed, that the disk is the correct way up in the drive (printed side upwards) and that it is a data CD. Remember that with a conventional CD-ROM drive you cannot write to a CD.

**Hard disk drives**

If you encounter problems accessing a hard disk drive, use the BIOS Setup utility to check that the drive is correctly specified, and that the drive's controller is enabled. Check also that the disk has been correctly formatted, and that the permissions assigned by the operating system allow the intended access.

# EQUIPMENT LOG

Use this equipment log to record information about your PC.

In particular, you must keep a record of the 12-digit fall-back password of the Electronic Fingerprinting security feature (see the *Getting Started* chapter for more information).

Record the password in the space provided below, then store this page (or the whole manual) in a safe place.

## Fall-back password:

--	--	--	--	--	--	--	--	--	--	--	--

## Manufacturer's data

You should record the model codes and serial numbers of the system components. You can update this with information about any expansion cards fitted.

	<b>Model</b>	<b>Serial number</b>
System unit		
Monitor		
Keyboard		
Mouse		
Speakers		
Sub-woofer		



## Equipment log

### Expansion cards

	Manufacturer	Description	Serial number
1			
2			
3			
4			
5			

### Other information

It may be useful to note any additional information here such as date of purchase, supplier, etc., along with the phone number of your maintenance provider.





16056531



**MITSUBISHI  
ELECTRIC**

**APRICOT PCs & SERVERS**

**MITSUBISHI ELECTRIC  
PC DIVISION**

Apricot Computers Limited  
3500 Parkside  
Birmingham Business Park  
Birmingham B37 7YS  
United Kingdom

Tel +44 (0) 121 717 7171  
Fax +44 (0) 121 717 7799

**MITSUBISHI ELECTRIC  
PC DIVISION**

Apricot Computers Limited  
Niederlassung Deutschland  
Gothaer Strasse 27  
40880 Ratingen  
Germany

Tel +49 (0) 2102 4556  
Fax +49 (0) 2102 455700

<http://www.mitsubishi-computers.com>